

**Sidewall Mount
Tension Sensors
Type SW**

In accordance with Nexen's established policy of constant product improvement, the specifications contained in this manual are subject to change without notice. Technical data listed in this manual are based on the latest information available at the time of printing and are also subject to change without notice.

Technical Support: 800-843-7445
(651) 484-5900

www.nexengroup.com

Nexen Group, Inc.
560 Oak Grove Parkway
Vadnais Heights, Minnesota 55127

ISO 9001 Certified

Copyright 2006 Nexen Group, Inc.



CAUTION

Read this manual carefully before installation and operation.

Follow Nexen's instructions and integrate this unit into your system with care.

This unit should be installed, operated and maintained by qualified personnel **ONLY**.

Improper installation can cause an interruption in service.

Comply with all applicable codes.

Table of Contents

General Information -----	1
Installation -----	3
Electrical Connections -----	5
Single Sensor Operation -----	5
Troubleshooting -----	6
Service Assistance and Repair -----	7
Parts Replacement -----	7
Warranty -----	8

GENERAL INFORMATION

RECEIVING AND UNPACKING

Handle and unpack the equipment carefully. Upon arrival, check the shipment against the packing list. Any damage should be reported immediately to the carrier and to your authorized Nexen Web Handling Distributor.

Equipment which will not be installed immediately should be stored in a clean, dry location. Precautions should be taken to prevent moisture, dust, and dirt from accumulating in storage and installation areas.

PRECAUTIONS

Shipping and Handling

The Tension Sensor must be removed when a machine is shipped.

The Tension Sensor must be completely surrounded by a soft foam cushion when being transported.

Roll Balance and Critical Roll Speed

The sensing roll must be dynamically balanced when the roll speed is 300 RPM or greater. The sensing roll must not be driven or have any force applied to it other than by the web. Excessive vibrations can damage the sensors.

Even with a balanced roll, a vibration can be set up in a stationary shaft. If this vibration (in cycles per minute) occurs at the harmonic frequency of the shaft, the Tension Sensors can be damaged. To determine the critical roll speed, use the

following formula:

$$\text{Critical roll speed (in RPM)} = \frac{4.8 \times 10^6 \times \text{Shaft O.D.}}{(\text{Shaft Length})^2}$$

All dimensions are in inches.

To assure this problem is avoided, the critical roll speed should at least be 20% above the roll speed attained at maximum web speed.

Overloading

Repetitive overloading above the maximum force, shock, or severe overloading should be avoided because it will damage the sensors.

SPECIFICATIONS

Gage Resistance

120 ohms per gage nominal

Excitation Voltage

6.0 VDC or VAC (RMS) maximum

Output Signal at Rated Maximum Force

250mV nominal per Tension Sensor (1/2 bridge)

500mV nominal per Tension Sensor pair (full bridge)

Output Impedance

Approximately 850 ohms per Tension Sensor (1/2 bridge) or 1700 ohms per pair (full bridge) (at 25° C, 77° F)

Required Input Impedance of Tension Amplifier

5 K ohms per Tension Sensor (1/2 bridge)

10 K ohms per pair (full bridge)

Operating Temperature

DESCRIPTION

Nexen Type SW Tension Sensors measure the web tension in unwind, intermediate, and rewind applications. They are appropriate where sidewall mounting of the sensors is required (Figure 1).

Nexen Type SW Tension Sensors can be mounted to the machine frame by means of a ring-shaped flange with four mounting bolts or by a single bolt extending through the side frame. The electrical connector is on the side of the sensor cartridge. For an illustration of the sensor and dimensions, see Figure 2 and Table 1.

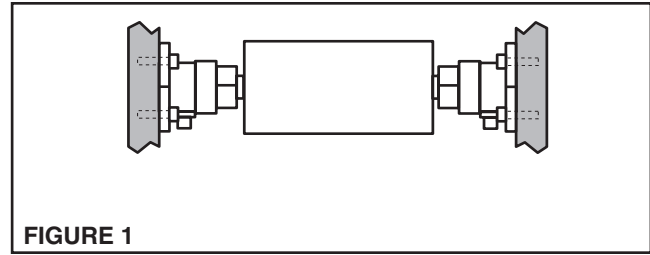

FIGURE 1

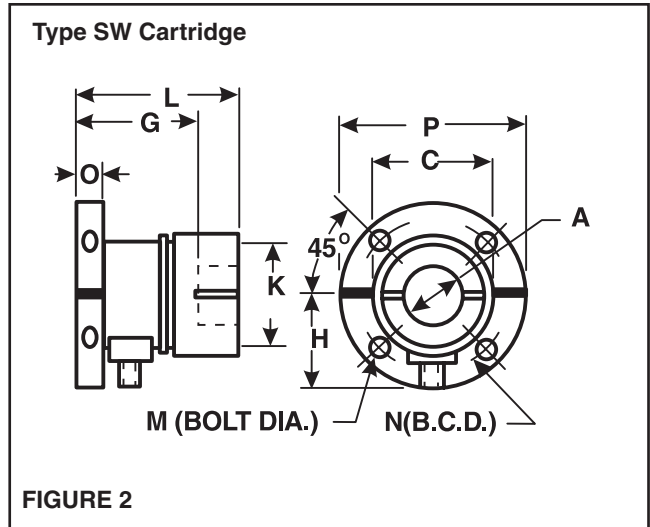
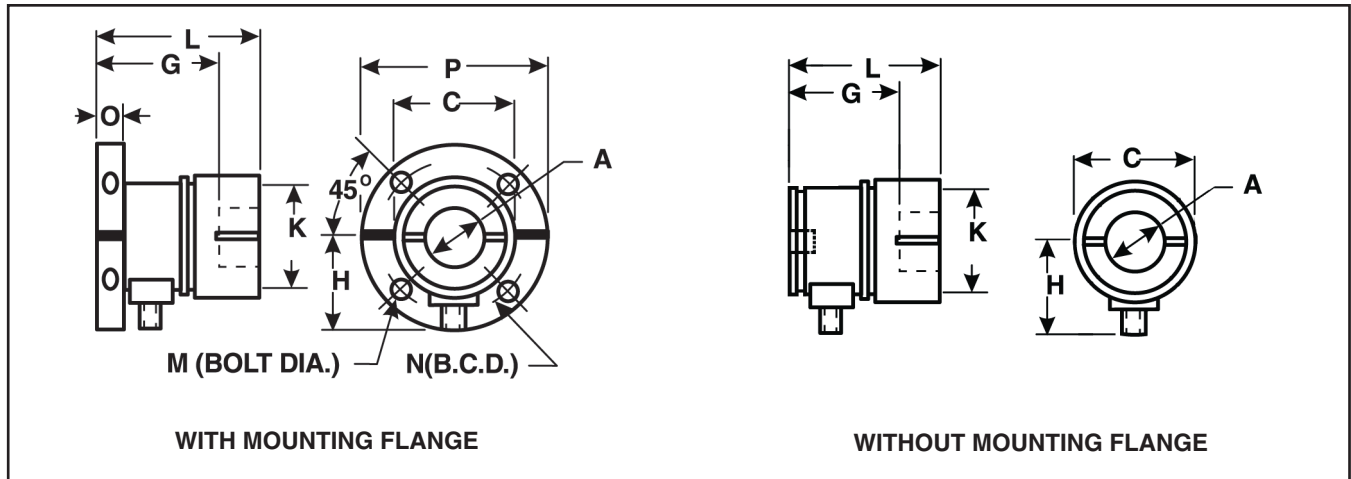

FIGURE 2

DIMENSIONS



	A	B	D	G	H	K	L	M	N	O	P
With Flange	1.25	1.95	N/A	2.61	1.77	2.26	3.18	13/32	3.25	0.59	4.00
Without Flange	1.25	1.95	1/2-13x 0.55DP	2.45	1.77	2.26	3.02	N/A	N/A	N/A	N/A

NOTES:

- All dimensions shown in inches.
- Allow 2-1/2 inches clearance for connector,
- Maximum roller shaft length = distance between sidewalls - (2xG)

TABLE 1

INSTALLATION

SELECTION OF SENSOR MOUNTING LOCATION

NOTE

When selecting a sensor mounting location, keep in mind the tension sensing roll must NOT be mounted where the web wrap can vary. Any change in wrap angle will be sensed by the sensors as a change in tension and indicated as such on the indicator.

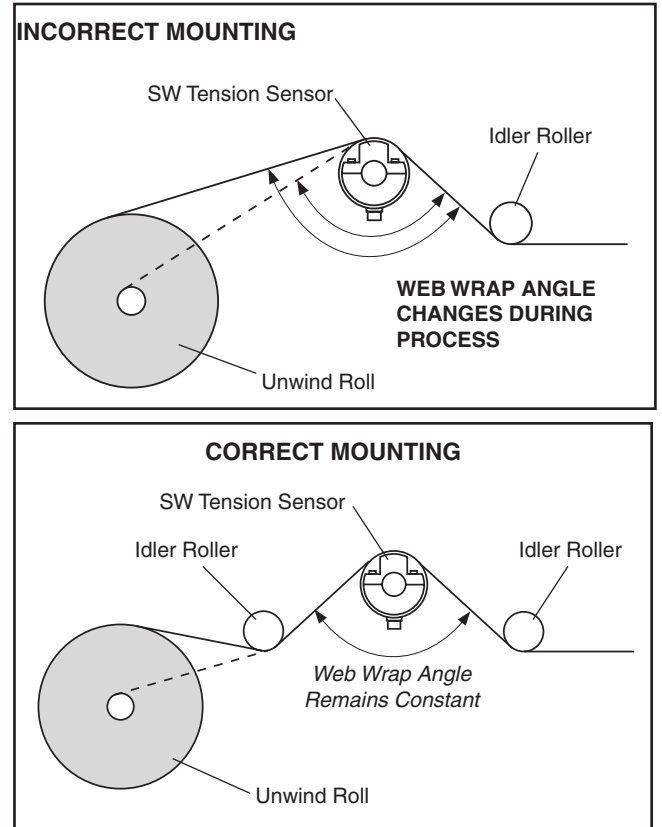

MOUNTING SURFACE PREPARATION

The mounting surfaces for the Tension Sensors should be flat and parallel. Prepare the machine frames or mounting surfaces by removing any loose paint, rust, scale, etc.

TENSION LOADING DIRECTION

The Tension Sensors must be mounted so the applied web force is approximately in line with the cable connector (Figure 3).

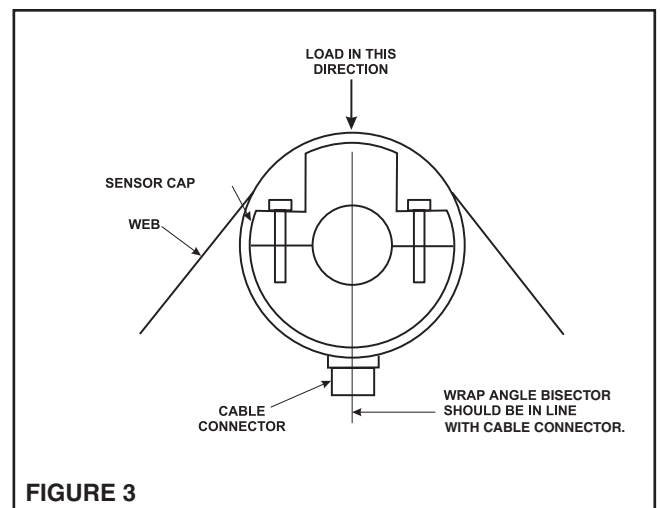

FIGURE 3

INSTALLATION PRECAUTIONS

CAUTION

To ensure proper installation and operation of the system, the following steps should be performed in sequence. Failure to do so could seriously damage the Tension Sensors and void the warranty.

Always install, orient, and firmly bolt down the sensor BEFORE installing the tension sensing roll.

When disassembling or installing, DO NOT remove the sensor and the tension sensing roll as an assembly—remove the roll first before loosening the sensor mounting bolts.

DO NOT rotate Tension Sensors (for orientation) with the tension sensing roll installed. Damage may result.

TENSION SENSOR INSTALLATION

The mounting holes should be drilled so the cable connector is in line with the resultant web force and will not interfere with the four sensor mounting bolts. The cable connector should bisect the web wrap angle. If present mounting holes are to be used or if for some reason new holes cannot be drilled, the split flange can be rotated relative to the sensor body.

In order to rotate the split flange, remove the sensor from the machine frame. Loosen the two bolts clamping the split flange to the sensor body. Rotate the split flange to the desired position and then retighten the two clamping bolts. If the cable connector is not lined up with the web force, there will be some loss in sensitivity.

SENSING ROLL INSTALLATION

After positioning the Tension Sensors, securely tighten the mounting bolts.

Check to see the Tension Sensors are parallel and in line. The Tension Sensors are designed to accommodate some frame to frame misalignment.

NOTE

Misalignment should be less than 1 degree.

Remove the sensor shaft caps by removing the four cap screws on each sensor.

Mount the tension sensing roll assembly in the Tension Sensors. Clearance between the end of the shaft and the sensor body should be from 1/16-1/64" [1.6-0.4 mm].

If shaft bushings are required, use split bushings of the correct length. Do not overhang the sensor I.D. and O.D. Do not use solid bushings. The lengthwise split in the bushing should be directly in line with the gap between the sensor cap and the sensor head. Securely fasten the sensor caps as shown in Figure 4.

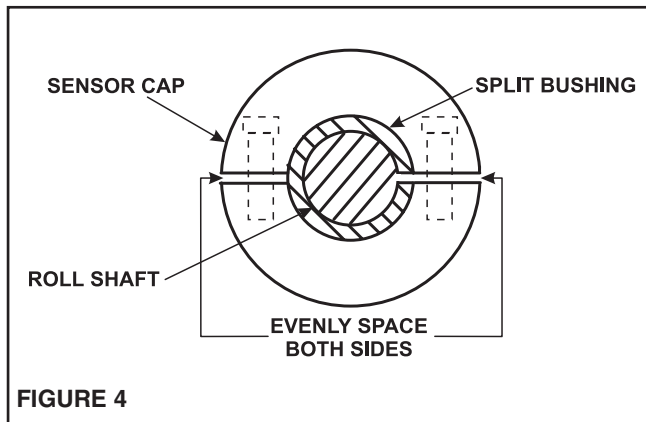

ELECTRICAL CONNECTIONS

Use the cables provided with the sensors and the installation wiring diagram supplied with the Nexen tension indicator or controller for making the transducer connections. Make certain the cables do not interfere with the web path and they are away from gearing or other moving parts. Use only the

Nexen supplied cables.

These wiring diagrams are for reference only for use with a dual (full bridge) sensor configuration (See Figure 5).

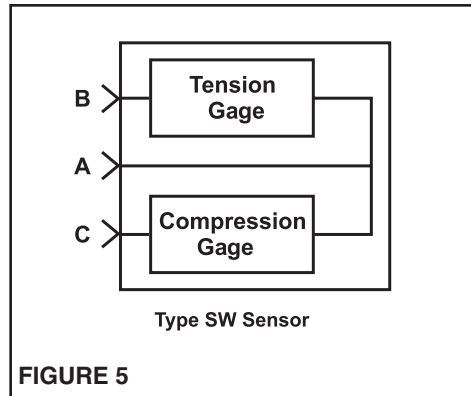

SINGLE SENSOR OPERATION

Single sensor operation requires the use of cable # 30517 and is not recommended by Nexen. The tension indicators and controllers will perform best when used with two sensors. For single sensor applications, consult with Nexen Web Technical Support.

TROUBLESHOOTING

PROBLEM	PROBABLE CAUSE	SOLUTION
Excessive output signal with no load.	There may be a high degree of misalignment of the sensor, causing a severe preload. The sensing roll assembly may be excessively heavy.	Correct sensor misalignment. The sensing roll should not weigh more than one-half the rated maximum Force of the sensors.
Low output signal.	Sensor has too large a rated maximum Force for the application.	Replace with a lower rated maximum Force sensor or increase the web wrap angle.
Output signal fails to increase with added load.	Sensors are overloaded and are hitting their mechanical stops.	Replace the sensors with ones having a higher rated maximum Force or reduce the load. (This may be accomplished by reducing the web wrap angle and/or using a lighter sensing roll).
Wrong polarity of output signal.	Sensors may be incorrectly oriented.	Rotate sensors 180 degrees. If rotation is impossible, interchange the sensors' output signal leads (green and white) at the tension meter or controller (See Figures 5, 6, and 7).
Output signal not linear, zero shifts during operation.	Check sensor and tension roll mounting. Check to be sure there is no dirt or foreign matter interfering with the sensor mounting.	Tighten all mounting bolts and remove dirt or foreign material.
No output signal.	Check to see all connections have been made completely. Check for places where the connecting cable might be crimped or cut.	Replace cables if necessary.
Very high output with no load.	Check cable and connector for good connections and check continuity of cable with an ohmmeter. Check for proper wiring to sensor. Check sensor gage resistance as given at room temperature with no load applied (See Table 2).	Replace cable, correct wiring, or replace sensor.

SENSOR GAGE RESISTANCE CHECK	
MEASUREMENT	RESISTANCE
Pin B to Pin C	195 ohms \pm 25 ohmx
Pin A to Pin B	95 ohms \pm 25 ohms
Pin A to Pin C	Equal to Pin A to Pin B \pm 5 ohms

TABLE 2

SERVICE ASSISTANCE AND REPAIR

CAUTION

Disassembly by improperly trained personnel may result in additional damage to the unit. Contact the factory if repairs become necessary.

For additional service assistance, please obtain the Nexen part number and serial number from the nameplate. Contact your authorized Nexen Distributor.

PARTS REPLACEMENT

Contact you local Nexen Distributor for parts availability. This unit is not field serviceable. The only field replaceable component is the cable.

SENSOR	
FORCE (lbs.)	PRODUCT NO.
25	803351
50	803352
75	803353
100	803354
150	803355
200	803356
CABLE	
LENGTH (ft.)	PRODUCT NO.
*16	*30518
25	15596
30	15869
50	15870

* Cable is included with each SW tension sensor.

WARRANTY

Warranties

Nexen warrants that the Products will be free from any defects in material or workmanship for a period of 12 months from the date of shipment. NEXEN MAKES NO OTHER WARRANTY, EXPRESS OR IMPLIED, AND ALL IMPLIED WARRANTIES, INCLUDING WITHOUT LIMITATION, IMPLIED WARRANTIES OF MERCHANTABILITY AND FITNESS FOR A PARTICULAR PURPOSE ARE HEREBY DISCLAIMED. This warranty applies only if (a) the Product has been installed, used and maintained in accordance with any applicable Nexen installation or maintenance manual for the Product; (b) the alleged defect is not attributable to normal wear and tear; (c) the Product has not been altered, misused or used for purposes other than those for which it was intended; and (d) Buyer has given written notice of the alleged defect to Nexen, and delivered the allegedly defective Product to Nexen, within one year of the date of shipment.

Exclusive Remedy

The exclusive remedy of the Buyer for any breach of the warranties set out above will be, at the sole discretion of Nexen, a repair or replacement with new, serviceably used or reconditioned Product, or issuance of credit in the amount of the purchase price paid to Nexen by the Buyer for the Products.

Limitation of Nexen's Liability

TO THE EXTENT PERMITTED BY LAW NEXEN SHALL HAVE NO LIABILITY TO BUYER OR ANY OTHER PERSON FOR INCIDENTAL DAMAGES, SPECIAL DAMAGES, CONSEQUENTIAL DAMAGES OR OTHER DAMAGES OF ANY KIND OR NATURE WHATSOEVER, WHETHER ARISING OUT OF BREACH OF WARRANTY OR OTHER

BREACH OF CONTRACT, NEGLIGENCE OR OTHER TORT, OR OTHERWISE, EVEN IF NEXEN SHALL HAVE BEEN ADVISED OF THE POSSIBILITY OR LIKELIHOOD OF SUCH POTENTIAL LOSS OR DAMAGE. For all of the purposes hereof, the term "consequential damages" shall include lost profits, penalties, delay images, liquidated damages or other damages and liabilities which Buyer shall be obligated to pay or which Buyer may incur based upon, related to or arising out of its contracts with its customers or other third parties. In no event shall Nexen be liable for any amount of damages in excess of amounts paid by Buyer for Products or services as to which a breach of contract has been determined to exist. The parties expressly agree that the price for the Products and the services was determined in consideration of the limitation on damages set forth herein and such limitation has been specifically bargained for and constitutes an agreed allocation of risk which shall survive the determination of any court of competent jurisdiction that any remedy herein fails of its essential purpose.

Limitation of Damages

In no event shall Nexen be liable for any consequential, indirect, incidental, or special damages of any nature whatsoever, including without limitation, lost profits arising from the sale or use of the Products.

Warranty Claim Procedures

To make a claim under this warranty, the claimant must give written notice of the alleged defect to whom the Product was purchased from and deliver the Product to same within one year of the date on which the alleged defect first became apparent.

nexen

Nexen Group, Inc.
560 Oak Grove Parkway
Vadnais Heights, MN 55127

800.843.7445
Fax: 651.286.1099
www.nexengroup.com

ISO 9001 Certified