

nexen

formerly Horton Industrial Products

"Air Champ"®



**NATIONAL ENGINEERING COMPANY
 NECO-1650 AND NECO-2200
 INSTALLATION, OPERATION, AND MAINTENANCE INSTRUCTIONS**

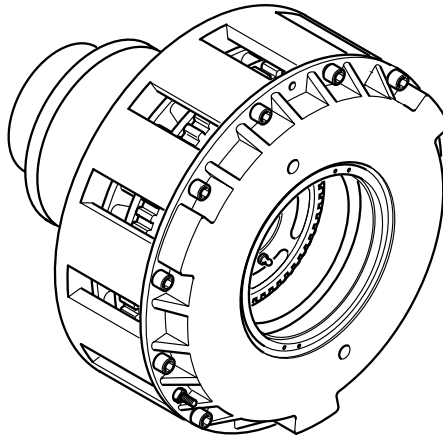

Read this manual carefully, making full use of its explanations and instructions. The "Know How" of safe, continuous, trouble-free operation depends on the degree of your understanding of the system and your willingness to keep all components in proper operating condition. Pay particular attention to all **NOTES, CAUTIONS, and WARNINGS** to avoid the risk of personal injury or property damage. It is important to understand that these **NOTES, CAUTIONS, and WARNINGS** are not exhaustive. Nexen cannot possibly know or evaluate all conceivable methods in which service may be performed, or the possible hazardous consequences of each method. Accordingly, anyone who uses a procedure that is not recommended by Nexen must first satisfy themselves that neither their safety or the safety of the product will be jeopardized by the service method selected.

CONTENTS

INSTALLATION -----2

AIR LINE CONNECTIONS -----3

LUBRICATION -----3

FRICION FACING INSPECTION -----4

TROUBLESHOOTING -----5

PARTS REPLACEMENT -----6

REPLACEMENT PARTS -----8

PARTS LIST -----9

INSTALLATION

NOTE

The Pilot Housing has a 1/2-13 UNC tapped hole on its outside diameter. A lifting ring may be threaded into this hole to aid in the mounting/dismounting of the clutch.

1. Apply a drop of Loctite® 242 to the threads of the eight 0.500-13 x 1.500" customer supplied socket head cap screws and lock washers; then, secure the sheave to the clutch (See Figure 1).
2. Alternately and evenly tighten the eight Socket Head Cap Screws to 114 Ft. Lbs. [153.83 N•m] torque.
3. Insert the customer supplied key into the motor shaft (See Figure 2).

NOTE

The motor shaft must be the proper size to allow installation of the clutch onto the motor shaft. The shaft bore of the clutch is machined to nominal motor shaft sizes $+0.001/-0.000$ ". Refer to Figure 3 for maximum and minimum motor shaft insertions.

4. Slide the clutch onto the motor shaft (See Figures 2 and 3).
5. Apply a drop of Loctite® 242 to the threads of the three Set Screws (Items 24 and 33); then, insert and tighten the three Set Screws (See Figure 2).

NOTE

Properly align sheave and tension the belts (see belt and sheave manufacturer tightening and alignment specifications).

CAUTION

Failure to align the sheaves will adversely affect clutch and motor bearing life, compromise belt wear, and cause belt squeal and vibration which leads to belts turning over and/or being thrown from the drive.

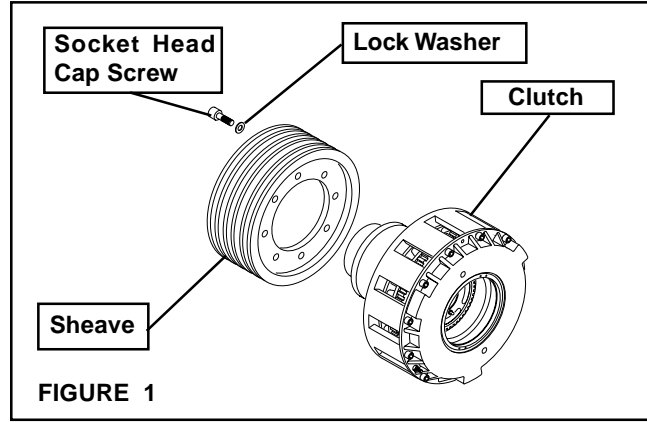

FIGURE 1

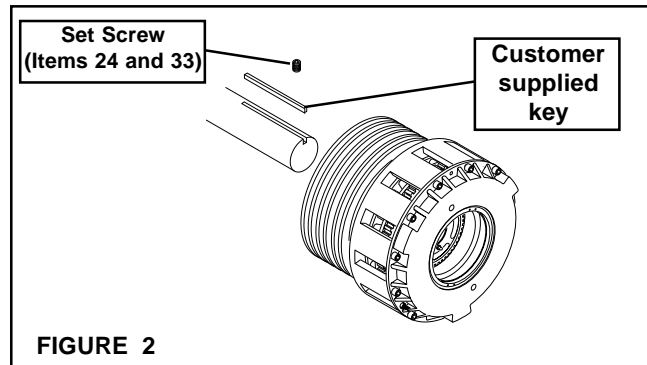

FIGURE 2

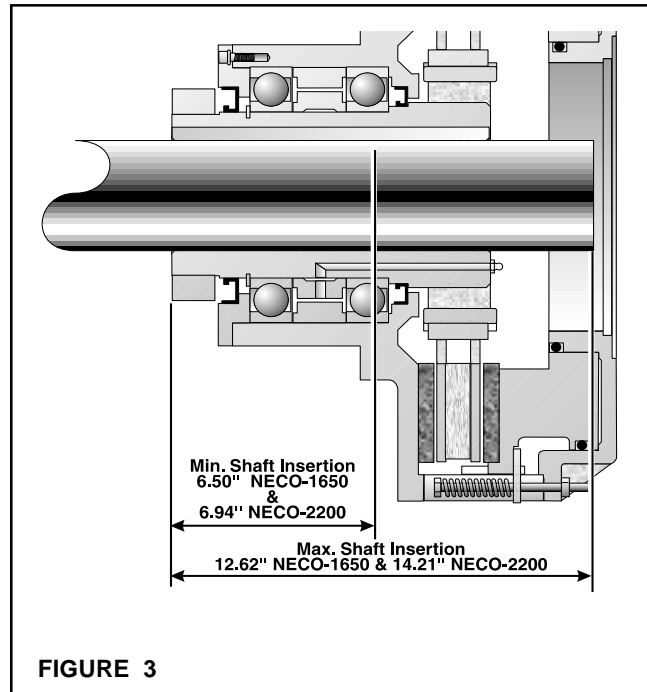

FIGURE 3

AIR LINE CONNECTIONS

1. If the Rotary Air Union (Item 30) and Rotary Air Union Bracket (Item 28) are not assembled, apply pipe sealant to the threads of the Rotary Air Union and screw the Rotary Air Union into the Rotary Air Union Bracket (See Figure 4).
2. Apply a drop of Loctite® 242 to the threads of the four Socket Head Cap Screws (Item 29) provided with the Rotary Air Union (Item 30) and Rotary Air Union Bracket (Item 28); then, secure the Rotary Air Union and Rotary Air Union Bracket to the clutch (See Figure 4).
3. Tighten the four Socket Head Cap Screws (Item 29) to 5.5 Ft. Lbs. [7.45 N•m] torque (See Figure 4).
4. Apply pipe sealant to the threads of the Elbow Fittings and install the Elbow Fittings into the Cylinder of the clutch and Rotary Air Union (See Figure 5).
5. Connect the two Hose Assemblies (Item 31) to the four Elbow Fittings (Item 35) (See Figure 5).
6. Connect Air Line to the Rotary Air Union (See Figure 5).

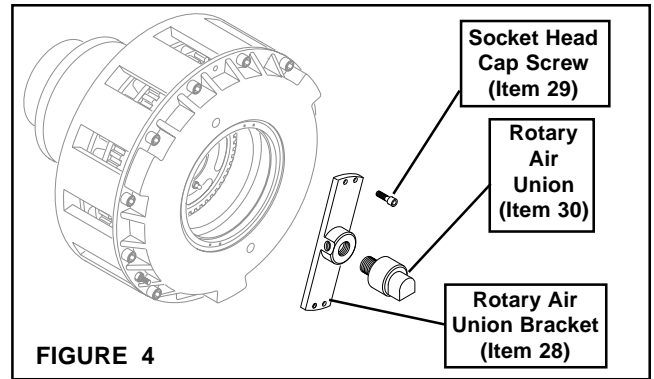

FIGURE 4

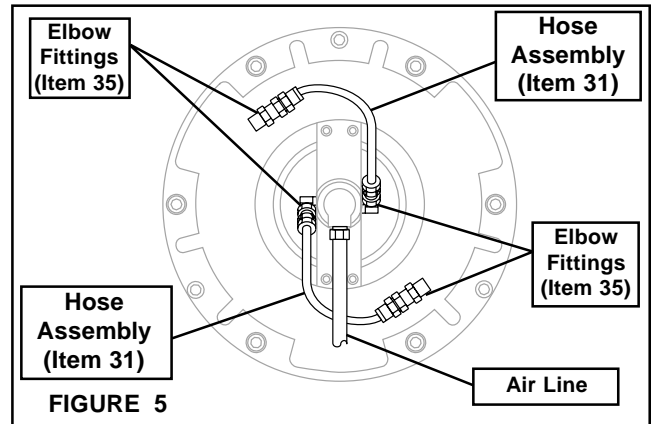

FIGURE 5

NOTE

Air Line must be routed as shown (See Figure 5).

Do not use rigid pipe or tubing for air lines.

LUBRICATION

NOTE

Pneumatically actuated devices require clean, pressure regulated, and lubricated air for maximum performance and long life. The most effective and economical way to lubricate Nexen Clutches and Brakes is with an Air Line Lubricator, which injects oil into the pressurized air, forcing an oil mist into the air chamber.

Locate the lubricator above and within ten feet of the Clutch or Brake, and use a low viscosity oil such as SAE-10.

Synthetic lubricants are not recommended.

LUBRICATOR DRIP RATE SETTINGS

NOTE

These settings are for Nexen supplied lubricators. If you are not using a Nexen lubricator, calibration must replicate the following procedure.

1. Close and disconnect the air line from the unit.
2. Turn the Lubricator Adjustment Knob clockwise three complete turns.
3. Open the air line.
4. Close the air line to the unit when a drop of oil forms in the Lubricator Sight Gage.
5. Connect the air line to the unit.
6. Turn the Lubricator Adjustment Knob counterclockwise until closed.
7. Turn the Lubricator Adjustment Knob clockwise one-third turn.
8. Open the air line to the unit.

BEARINGS

Lubricate the Bearings after every forty hours of operation by applying two to three strokes of grease with a hand grease gun (See Figure 6).

NOTE

Nexen recommends the use of Chevron SRI #2 or equivalent.

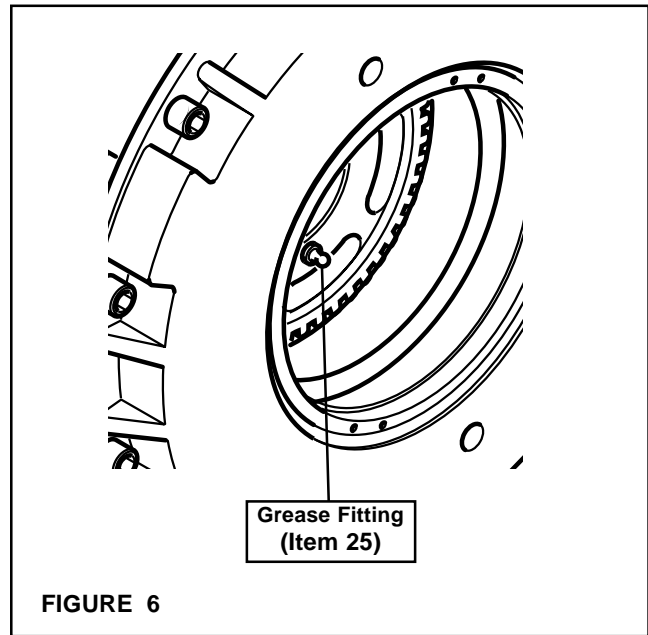

FRICITION FACING INSPECTION

Visually inspect the Friction Facings after every forty hours of operation. Replace the friction facings when the remaining material is 5/16" thick. Use a scale to measure the thickness on the NECO-2200.

The NECO-1650 has steps in the friction facing which indicate 5/16" thickness. When the steps are no longer visible, the facings need to be replaced (See Figure 7).

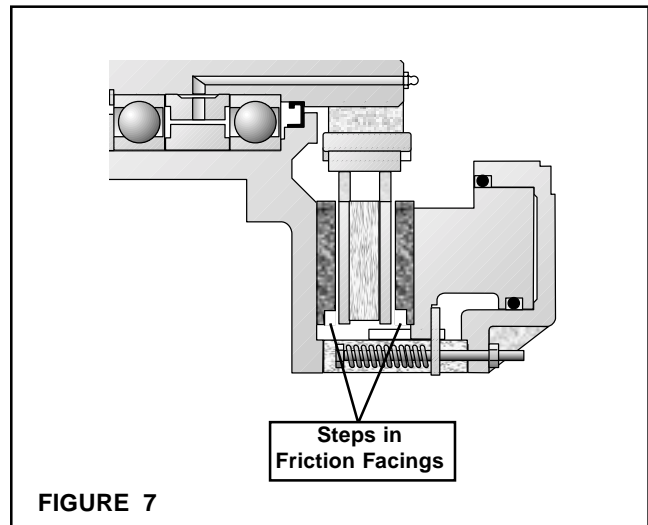

TROUBLESHOOTING

SYMPTOM	PROBABLE CAUSE	SOLUTION
Failure to disengage.	Unexhausted air due to a control valve malfunction.	Replace the control valve.
	Rigid piping or tubing used for air lines.	Use flexible tubing for air lines.
	Weak or broken Compression Springs.	Replace the Compression Springs.
Failure to engage.	Air not getting to clutch due to a control valve malfunction.	Replace the control valve.
	Friction lock due to a lack of lubrication in the air chamber.	Check air line lubricator.
Loss of torque.	Worn or contaminated Friction Facings.	Replace the Friction Facings.

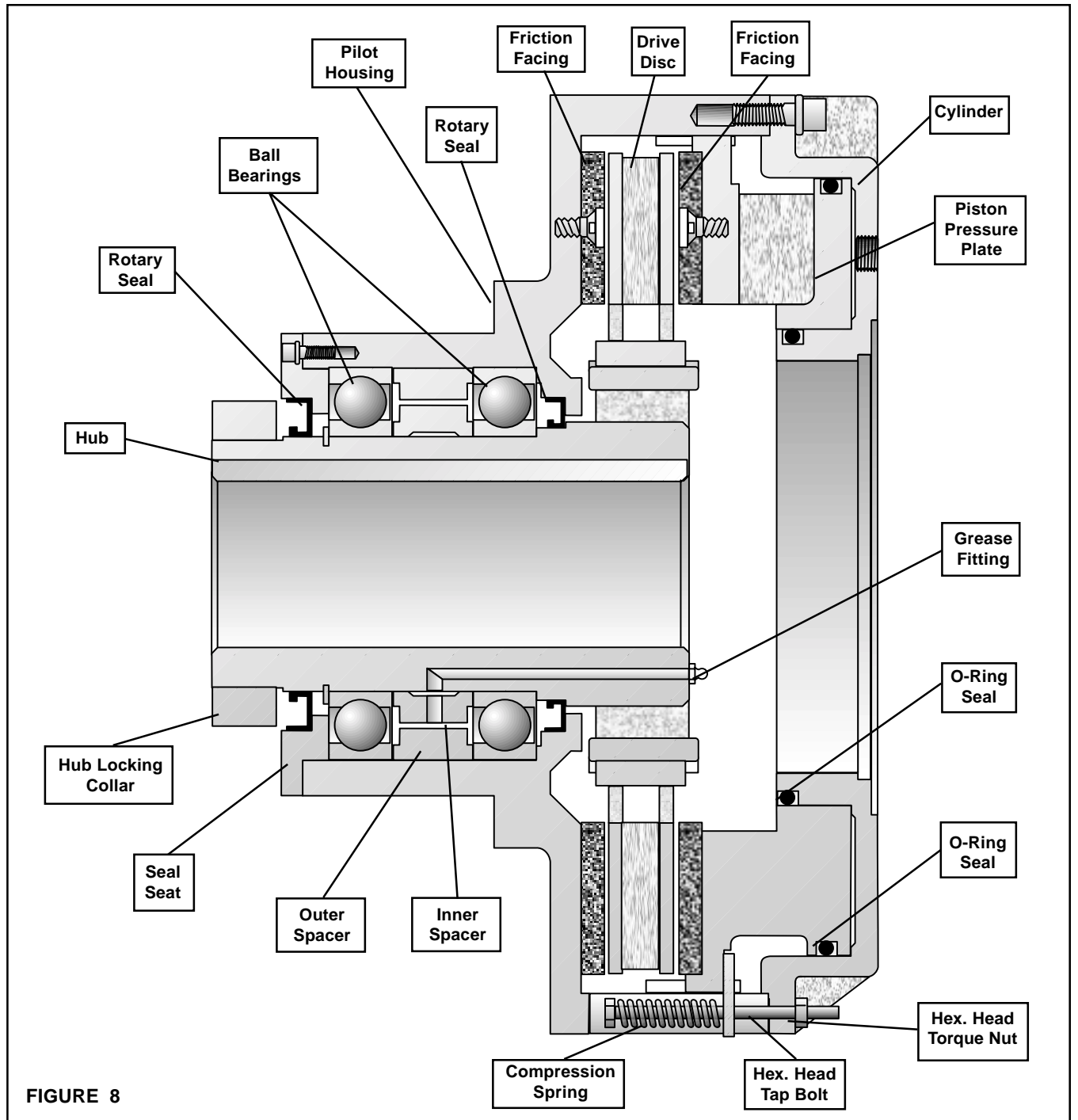

FIGURE 8

PARTS REPLACEMENT

FRICITION FACING and O-RING SEAL REPLACEMENT

NOTE

The clutch does not have to be removed from the motor shaft to replace the Friction Facings and O-Ring Seals.

1. Remove the Hex. Head Torque Nuts (Item 19) (See Figure 9).
2. Remove the twelve Socket Head Cap Screws (Item 14) and Lock Washers (Item 20) (See Figure 9).
3. Remove the Cylinder (Item 5) (See Figure 9).

NOTE

Applying low air pressure aids in the separation of the Cylinder (Item 5) from the Piston/Pressure Plate (Item 6) (See Figure 9).

4. Slide the Piston/Pressure Plate (Item 6) out of the Pilot Housing (Item 2) (See Figure 9).
5. Slide the Drive Disc (Item 4) off the Hub (Item 1) (See Figure 9).

NOTE

If the Ball Bearings (Item 12) and Rotary Seals (Items 7 and 27) are being replaced, proceed with BALL BEARING and ROTARY SEAL REPLACEMENT, Page 7.

NOTE

The Flat Head Screws (Item 13) are assembled with an anaerobic thread locking compound. Inserting a properly fitting screwdriver into the head of the Flat Head Screw and striking the end of the screwdriver with a hammer will break the crystalline structure of the locking compound and allow removal of the Flat Head Screws. Never use an impact wrench to remove the Flat Head Screws.

6. Remove the old Flat Head Screws (Item 13) and the old Friction Facings (Item 3) from the Pilot Housing (Item 2) (See Figure 9).
7. Using new Flat Head Screws (Item 13), install the new Friction Facings (Item 3) (See Figure 9).
8. Tighten the new Flat Head Screws (Item 13) to 16 Ft. Lbs. [21.59 N•m] torque (See Figure 9).
9. Slide the Drive Disc (Item 4) back onto the Hub (Item 1) (See Figure 9).
10. Remove the old Flat Head Screws (Item 13) and the old Friction Facings (Item 3) from the Piston/Pressure Plate (Item 6) (See Figure 9).
11. Using new Flat Head Screws (Item 13), install the new Friction Facings (Item 3) (See Figure 9).

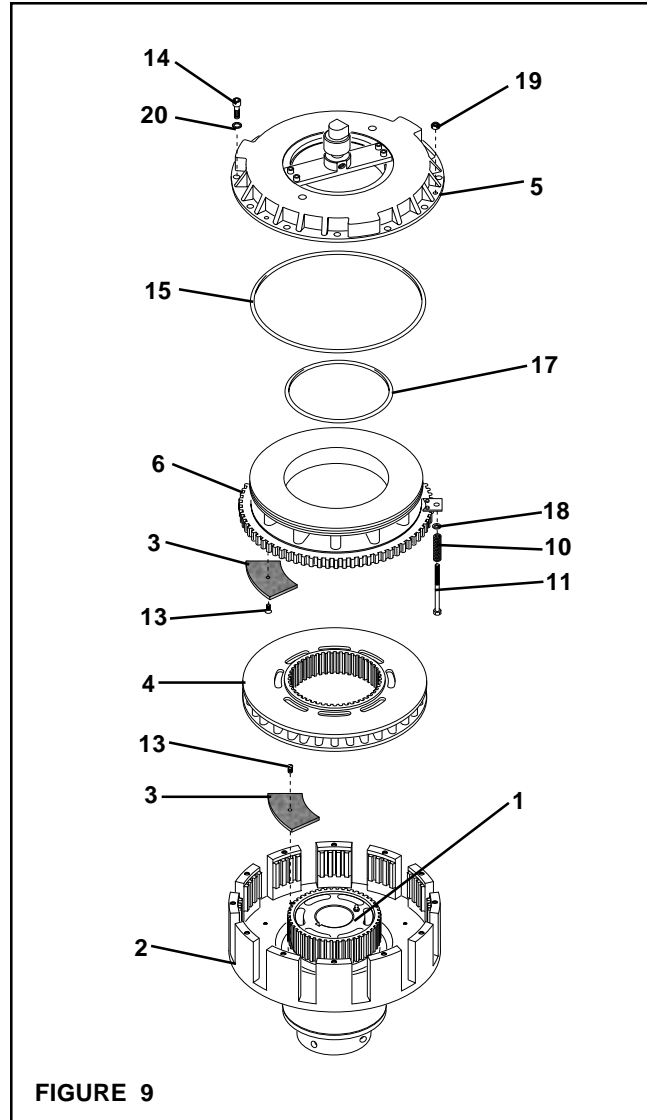

FIGURE 9

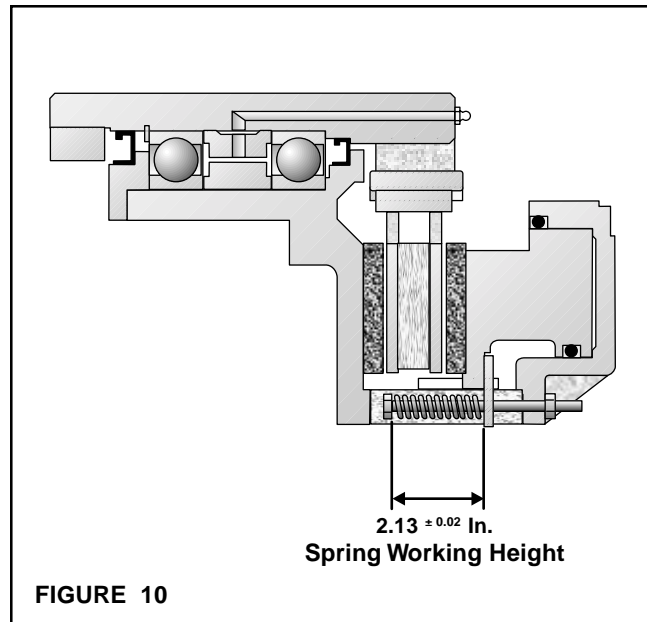

FIGURE 10

12. Tighten the new Flat Head Screws (Item 13) to 16 Ft. Lbs. [21.59 N•m] torque (See Figure 9).
13. Remove the old O-Ring Seal (Item 15) from the Piston/Pressure Plate (Item 6) (See Figure 9).
14. Coat the new O-Ring Seal (Item 15) with Parker® O-Ring lubricant and install the new O-Ring Seal on the Piston/Pressure Plate (Item 6) (See Figure 9).
15. Slide the Piston/Pressure Plate (Item 6) back into the Pilot Housing (Item 2) (See Figure 9).
16. Remove the old O-Ring Seal (Item 17) from the Cylinder (Item 5) (See Figure 9).
17. Coat the new O-Ring Seal (Item 17) with Parker® O-Ring lubricant and install the new O-Ring Seal on the Cylinder (Item 5) (See Figure 9).
18. Slide the Cylinder (Item 5) onto the Piston/Pressure Plate (Item 6) and Pilot Housing (Item 2) (See Figure 9).
19. Apply a drop of Loctite® 242 to the threads of the twelve Socket Head Cap Screws (Item 14) (See Figure 9).
20. Install the twelve Socket Head Cap Screws (Item 14) and Lock Washers (Item 20) (See Figure 9).
21. Alternately and evenly tighten the twelve Socket Head Cap Screws to 110 Ft. Lbs. [148.43 N•m] torque.
22. Install the Hex. Head Torque Nuts (Item 19) (See Figure 9).
23. Tighten the Hex. Head Torque Nuts (Item 19) until a spring working height of 2.13 In. [51.2 mm] is achieved (See Figure 10).

BALL BEARING and ROTARY SEAL REPLACEMENT

NOTE

The clutch must be removed from the motor to replace the Ball Bearings and Rotary Seals. Two 1/2"-13 tapped holes are provided in the Hub to aid in removing the clutch from the motor shaft and lifting the Hub out of the Pilot Housing.

1. Proceed with Steps 1-6 of FRICTION FACING and O-RING SEAL REPLACEMENT, Page 6.
2. Remove the Socket Head Cap Screws securing the Sheave to the clutch and remove the Sheave.
3. Remove the three Set Screws (Items 24 and 33) and the Hub Locking Collar (Item 23) (See Figure 11).
4. Remove the six Socket Head Cap Screws (Item 26) (See Figure 11).
5. Remove the Seal Seat (Item 22) and the old Rotary Seal (Item 7) (See Figure 11).

WARNING

Special attention should be exercised when working with retaining rings. Always wear safety goggles when working with spring or tension loaded fasteners or devices.

6. Remove the Retaining Ring (Item 21) (See Figure 11).
7. Press the Hub (Item 1) out of the Ball Bearings (Item 12) and Pilot Housing (Item 2) (See Figure 11).
8. Press the two old Ball Bearings (Item 12) and Spacers (Items 16 and 34) out of the Pilot Housing (Item 2) (See Figure 11).
9. Press the old Rotary Seal (Item 27) out of the Pilot Housing (Item 2) (See Figure 11).

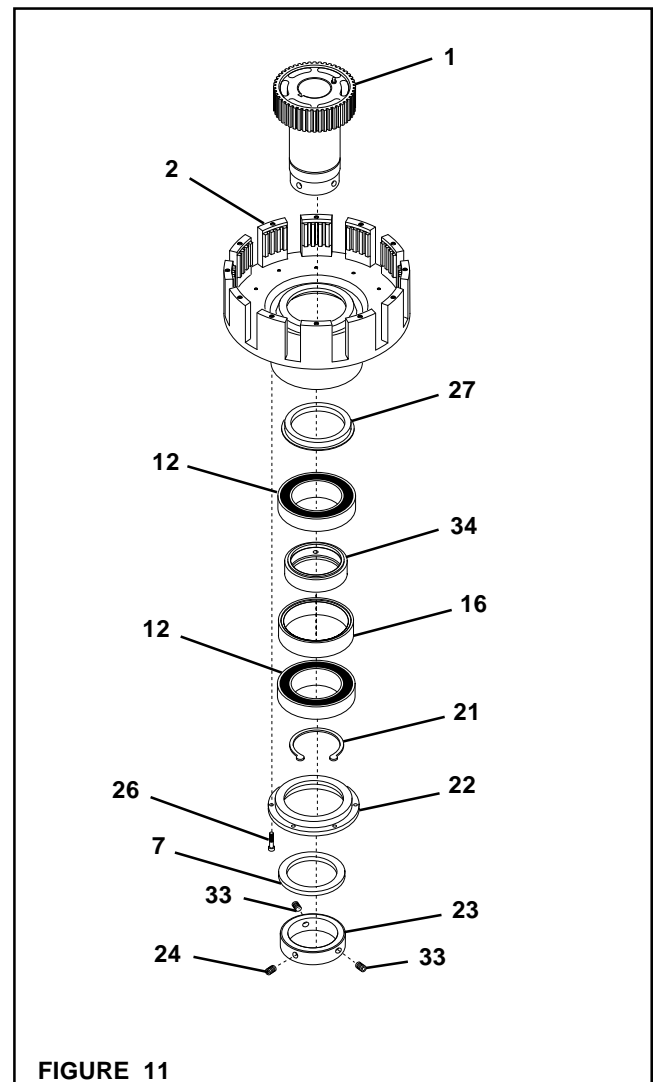

NOTE

The Pilot Housing bore must be $7.8740^{+0.0012}/_{-0.000}$ " for NECO 1650 and $9.0551^{+0.0012}/_{-0.0000}$ " for NECO 2200. The Hub diameter must be $5.1189^{+0.0000}/_{-0.0007}$ ".

- Clean the bore of the Pilot Housing (Item 2) with fresh safety solvent, making sure all old Loctite® residue is removed; then, check the diameter of the bore of the Pilot Housing (Item 2) and the Hub (Item 1).

NOTE

The clutch may have different styles of Rotary Seals (Items 7 and 27). Refer to Figures 12 and 13 for correct positioning of the Rotary Seals for the clutch you are working on.

- Press a new Rotary Seal (Item 27) into the Pilot Housing (Item 2) (See Figures 11, 12, and 13).
- Apply an adequate amount of Loctite® 680 to coat the outer race of the first new Ball Bearing (Item 12) and press it into the Pilot Housing (Item 2) (See Figure 11).
- Reinstall the Spacers (Item 16 and 34) (See Figure 11).
- Apply an adequate amount of Loctite® 680 to coat the outer race of the second new Ball Bearing (Item 12) and press it into the Pilot Housing (Item 2) (See Figure 11).
- Support the inner and outer races of the Ball Bearings (Item 12) and press the Hub (Item 1) back into the Ball Bearings (Item 12) and Pilot Housing (Item 2) (See Figure 11).
- Reinstall the Retaining Ring (Item 21) (See Figure 11).
- Reinstall the Seal Seat (Item 22) (See Figure 11).
- Apply a drop of Loctite® 242 to the threads of the Socket Head Cap Screw (Item 26); then, install the Socket Head Cap Screw (Item 26) (See Figure 11).
- Tighten the Socket Head Cap Screw (Item 26) to 12 Ft. Lbs. [16.19 N•m] torque (See Figure 11).
- Press a new Rotary Seal (Item 7) into the Seal Seat (Item 22) (See Figures 11 and 12).

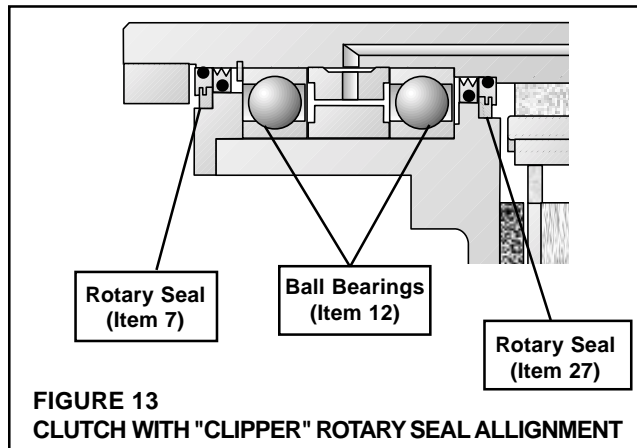
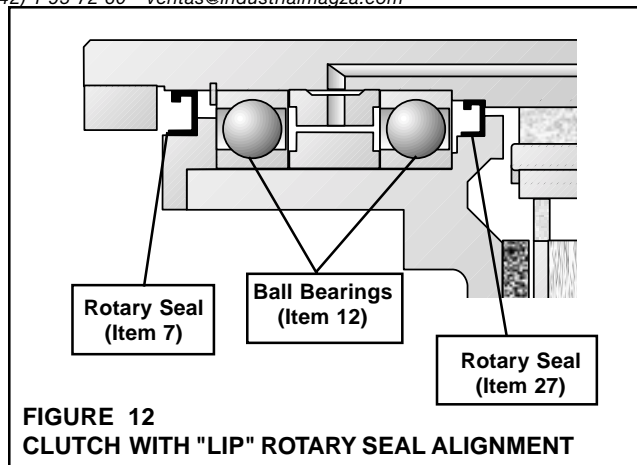

NOTE

Nexen recommends the use of Chevron SRI #2 or equivalent.

- Lubricate the Ball Bearings (Item 12) until grease weeps past Rotary Seal (Item 7) (See Figures 12 and 13).
- Secure the Sheave to the clutch (See INSTALLATION, Page 2).
- Reinstall the Hub Locking Collar (Item 23) and Set Screws (Items 24 and 33).
- Proceed with Steps 6-20 for FRICTION FACING and O-RING SEAL REPLACEMENT, Page 6.

REPLACEMENT PARTS

The item or balloon number for all Nexen products is used for part identification on all product parts lists, product price lists, unit assembly drawings, bills of materials, and instruction manuals.

When ordering replacement parts, specify model designation, item number, part description, and quantity. Purchase replacement parts through your local Nexen Distributor.

PARTS LIST

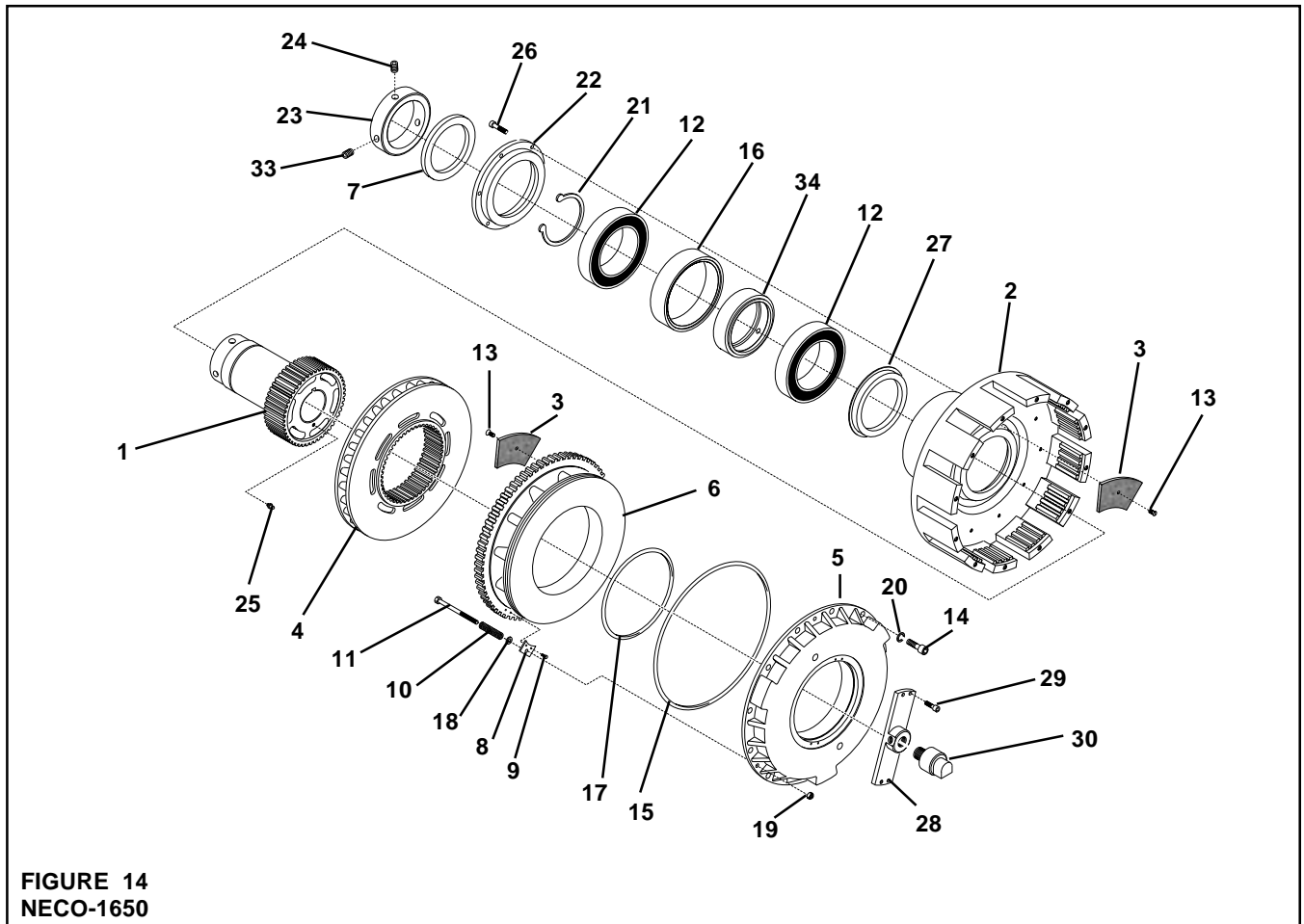

FIGURE 14
NECO-1650

ITEM	DESCRIPTION	QTY
1	Hub (3.375" Bore)	1
2	Pilot Housing	1
3 ²	Friction Facing	12
4	Drive Disc	1
5	Cylinder	1
6	Piston/Pressure Plate	1
7 ¹	Rotary Seal	1
8	Spring Retaining Bracket	3
9	Socket Head Cap Screw	6
10 ¹	Compression Spring	3
11	Hex. Head Tap Bolt	3
12 ¹	Ball Bearing	2
13 ²	Flat Head Screw	24
14	Socket Head Cap Screw	12
15 ¹	O-Ring Seal	1
16	Outer Spacer	1
17 ¹	O-Ring Seal	1

ITEM	DESCRIPTION	QTY
18	Flat Washer	3
19	Hex. Head Torque Nut	3
20	Lock Washer	12
21	Retaining Ring (Ext.)	1
22	Seal Seat	1
23	Hub Locking Collar	1
24	Set Screw	1
25	Grease Fitting	1
26	Socket Head Cap Screw	6
27 ¹	Rotary Seal	1
28	Rotary Air Union Bracket	1
29	Socket Head Cap Screw	4
30	Rotary Air Union	1
31	Hose Assembly (Not Shown)	2
33	Set Screw	2
34	Inner Spacer	1
35	Elbow Fitting (Not Shown)	4

¹ Denotes Rebuild Kit items.
NECO-1650 Lip Seal Style Rebuild Kit No. 964065.

² Denotes Facing Kit items.
NECO-1650 Facing Kit No. 964071.

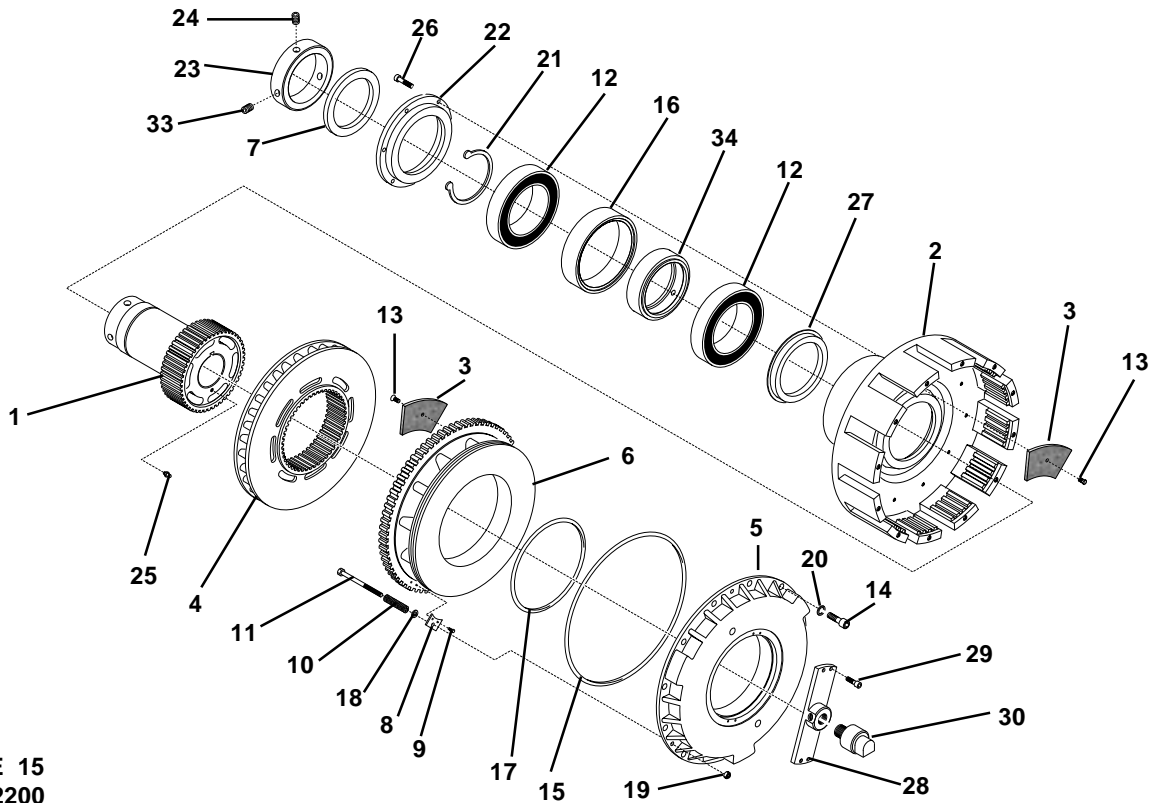

FIGURE 15
NECO-2200

ITEM	DESCRIPTION	QTY
1	Hub (3.375" Bore)	1
2	Pilot Housing	1
3 ²	Friction Facing	12
4	Drive Disc	1
5	Cylinder	1
6	Piston/Pressure Plate	1
7 ¹	Rotary Seal	1
8	Spring Retaining Bracket	6
9	Socket Head Cap Screw	12
10 ¹	Compression Spring	6
11	Hex. Head Tap Bolt	6
12 ¹	Ball Bearing	2
13 ²	Flat Head Screw	24
14	Socket Head Cap Screw	12
15 ¹	O-Ring Seal	1
16	Outer Spacer	1
17 ¹	O-Ring Seal	1

ITEM	DESCRIPTION	QTY
18	Flat Washer	6
19	Hex. Head Torque Nut	6
20	Lock Washer	12
21	Retaining Ring (Ext.)	1
22	Seal Seat	1
23	Hub Locking Collar	1
24	Set Screw	1
25	Grease Fitting	1
26	Socket Head Cap Screw	6
27 ¹	Rotary Seal	1
28	Rotary Air Union Bracket	1
29	Socket Head Cap Screw	4
30	Rotary Air Union	1
31	Hose Assembly (Not Shown)	2
33	Set Screw	2
34	Inner Spacer	1
35	Elbow Fitting (Not Shown)	4

¹ Denotes Rebuild Kit items.

NECO-2200 Clipper Seal Style Rebuild Kit No. 964105.

NECO-2200 Lip Seal Style Rebuild Kit No. 964148.

² Denotes Facing Kit items.

NECO-2200 Facing Kit No. 964106.

WARRANTY

Nexen Group, Inc. (Nexen) warrants its product(s) [the Product(s)] will be free from defects in materials and workmanship under normal use and service conditions for a period of 12 months from the date of shipment. NO OTHER WARRANTIES, WHETHER EXPRESS, IMPLIED, OR STATUTORY, INCLUDING WITHOUT LIMITATION WARRANTIES OF MERCHANTABILITY, OR OF FITNESS FOR A PARTICULAR PURPOSE, ARE GIVEN, AND ALL SUCH OTHER WARRANTIES ARE HEREBY EXPRESSLY DISCLAIMED.

Conditions

This warranty applies only if: (a) the Product has been installed, used, and maintained in accordance with any applicable Nexen installation or maintenance manual for the Product; (b) the alleged defect is not attributable to normal wear and tear; (c) the Product has not been altered, misused, or used for purposes other than those for which it was intended; and (d) the claimant has complied with the warranty claim procedures set out below in Warranty Claim Procedures.

Exclusive Remedy

The sole and exclusive remedy for a breach of this warrant shall be, at Nexen's sole election, repair or replacement with new, serviceably used or reconditioned Product, or issuance of a credit in the amount of the current Nexen discounted price for the Product.

Limitation of Damages

In no event shall Nexen be liable for any consequential, indirect, incidental, or special damages of any nature whatsoever, including without limitation, lost profits arising from the sale or use of the Products.

Warranty Claim Procedures

To make a claim under this warranty, the claimant must give written notice of the alleged defect to Nexen and deliver the Product to Nexen within one year of the date on which the alleged defect first became apparent

Nexen Group, Inc.
 560 Oak Grove Parkway
 Vadnais Heights, MN 55127
 800-843-7445
 In MN: (651) 484-5900
 Fax: (651) 286-1099
 www.nexengroup.com
 ISO 9001 Certified