

nexen

AIR CHAMP® PRODUCTS

User Manual



Brake

Model BC425A

Product No. 835215

In accordance with Nexen's established policy of constant product improvement, the specifications contained in this manual are subject to change without notice. Technical data listed in this manual are based on the latest information available at the time of printing and are also subject to change without notice.

Technical Support:
800-843-7445
(651) 484-5900

www.nexengroup.com



WARNING

Read this manual carefully before installation and operation.

Follow Nexen's instructions and integrate this unit into your system with care.

This unit should be installed, operated and maintained by qualified personnel **ONLY**.

Improper installation can damage your system or cause injury or death.

Comply with all applicable codes.

Nexen Group, Inc.
560 Oak Grove Parkway
Vadnais Heights, Minnesota 55127

TABLE OF CONTENTS

Introduction 1

Maintenance 1

Parts Replacement 2

Replacement Parts 3

Parts List 3

Warranties 4

INTRODUCTION

Read this manual carefully, making full use of its explanations and instructions. The “Know How” of safe, continuous, trouble-free operation depends on the degree of your understanding of the system and your willingness to keep all components in proper operating condition. Pay particular attention to all NOTES, CAUTIONS, and WARNINGS to avoid the risk of personal injury or property damage. It is important to understand that these NOTES, CAUTIONS, and WARNINGS are not exhaustive. Nexen cannot possibly know or evaluate all conceivable methods in which service may be performed, or the possible hazardous consequences of each method. Accordingly, anyone who uses a procedure that is not recommended by Nexen must first satisfy themselves that neither their safety or the safety of the product will be jeopardized by the service method selected.

MAINTENANCE

AIR CONNECTIONS

Pneumatically actuated devices require clean pressure regulated air for maximum performance and long life. Nexen recommends that a filter, and regulator be used on the air line ahead of the air controls.

For optimal engagement and disengagement connect the air controls as close to the brake as possible. When

long air lines are required, the use of a quick exhaust valve is recommended.

Check the air lines for leaks during routine ride inspection. If any air leaks are detected, the cause of the air leak must be corrected before placing the brake back in service.

FASTENERS

Check all fasteners for tightness during the routine ride inspection (Refer to Table 1 for Tightening Torques).

TABLE 1

DESCRIPTION	SIZE	TORQUE
Shoulder Screw (Item 11)	3/8-16	20 Ft. Lbs.
Hex Nut (Item 17)	1/2-13	45 Ft. Lbs.
Mounting Cap Screws, Soc. Hd.	1/2-13	45 Ft. Lbs.

FRICION FACINGS

Replace the Friction Facings when they are worn to approximately $\frac{1}{16}$ inch thick.

PARTS REPLACEMENT

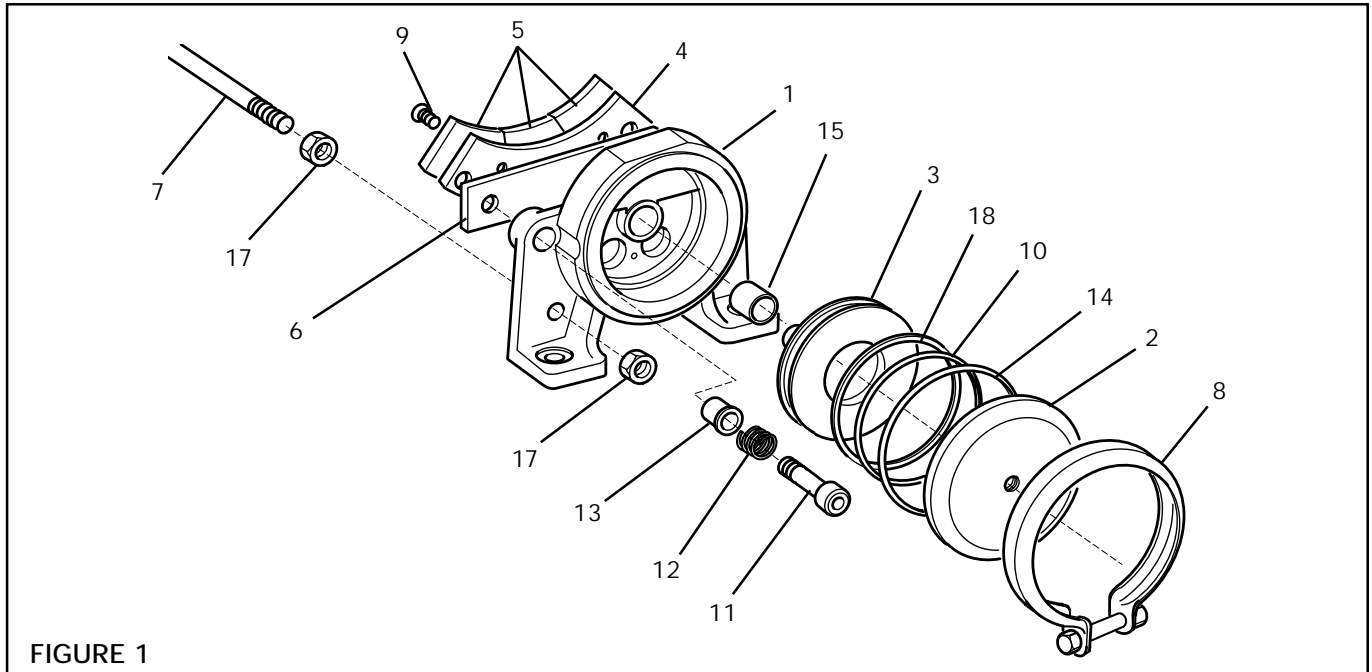

FIGURE 1

1. Remove Shoulder Screws (Item 11) and Springs (Item 12) (See Fig. 1).

CAUTION

Shoulder Screws (Item 11) are spring loaded. Always wear safety goggles when working with spring or tension loaded fasteners or devices.

2. Remove Spacer (Item 6), Shoe (Item 4), and Friction Facings (Item 5) (See Fig. 1).
3. Remove Machine Screws (Item 9), securing the Friction Facings to the Shoe (See Fig. 1).
4. Remove old Friction Facings, and using new Machine Screws, install new Friction Facings.
5. Tighten Machine Screws (Item 9) to 5 Ft. Lbs. torque.
6. Remove the Clamp Bolt from the Ring Clamp (Item 8) (See Fig. 1).
7. Remove the Ring Clamp (Item 8) (See Fig. 1).
8. From the back side of the Cylinder (Item 1), push the Piston (Item 3) and End Cap (Item 2) out of the Cylinder (See Fig. 1).
9. Remove the Back-Up Seal (Item 18) and O-ring Seal (Item 10) from the Piston (Item 3) (See Fig. 1).
10. Remove the O-ring Seal (Item 14) from the End Cap (Item 2) (See Fig. 1).

11. Clean seal contact surfaces of the Piston (Item 3) and End Cap (Item 2) with fresh safety solvent.

12. Lubricate seal contact surfaces of the Piston and End Cap with fresh O-ring lubricant.

13. Lubricate O-ring Seals (Items 10 & 14), and Back-Up Seal (Item 18) with fresh O-ring lubricant.

14. Install new O-ring Seal (Item 10) and Back-Up Seal (Item 18) onto Piston (Item 3) (See Fig. 1).

NOTE: Back-Up Seal must be installed on the non-pressurized side of the Piston.

15. Slide Piston and Seals into the Cylinder.

16. Install new O-ring Seal (Item 14) onto End Cap (Item 2).

17. Slide End Cap and O-ring Seal into Cylinder.

18. Install Ring Clamp (Item 8) and tighten Clamp Bolt.

19. Insert Shoulder Screws (Item 11), and Springs (Item 12) through the Cylinder (Item 1), and Spacer (Item 6) (See Fig. 1).

20. Screw the Shoulder Screws (Item 11) into the Friction Facing Shoes (Item 4) (See Fig. 1).

21. Tighten Shoulder Screws to 20 Ft. Lbs. torque.

REPLACEMENT PARTS

The item or balloon number for all Nexen products is used for part identification on all product parts lists, product price lists, unit assembly drawings, bills of materials, and instruction manuals.

When ordering replacement parts, specify model designation, item number, part description, and quantity. Purchase replacement parts through your local Nexen Distributor.

PARTS LIST

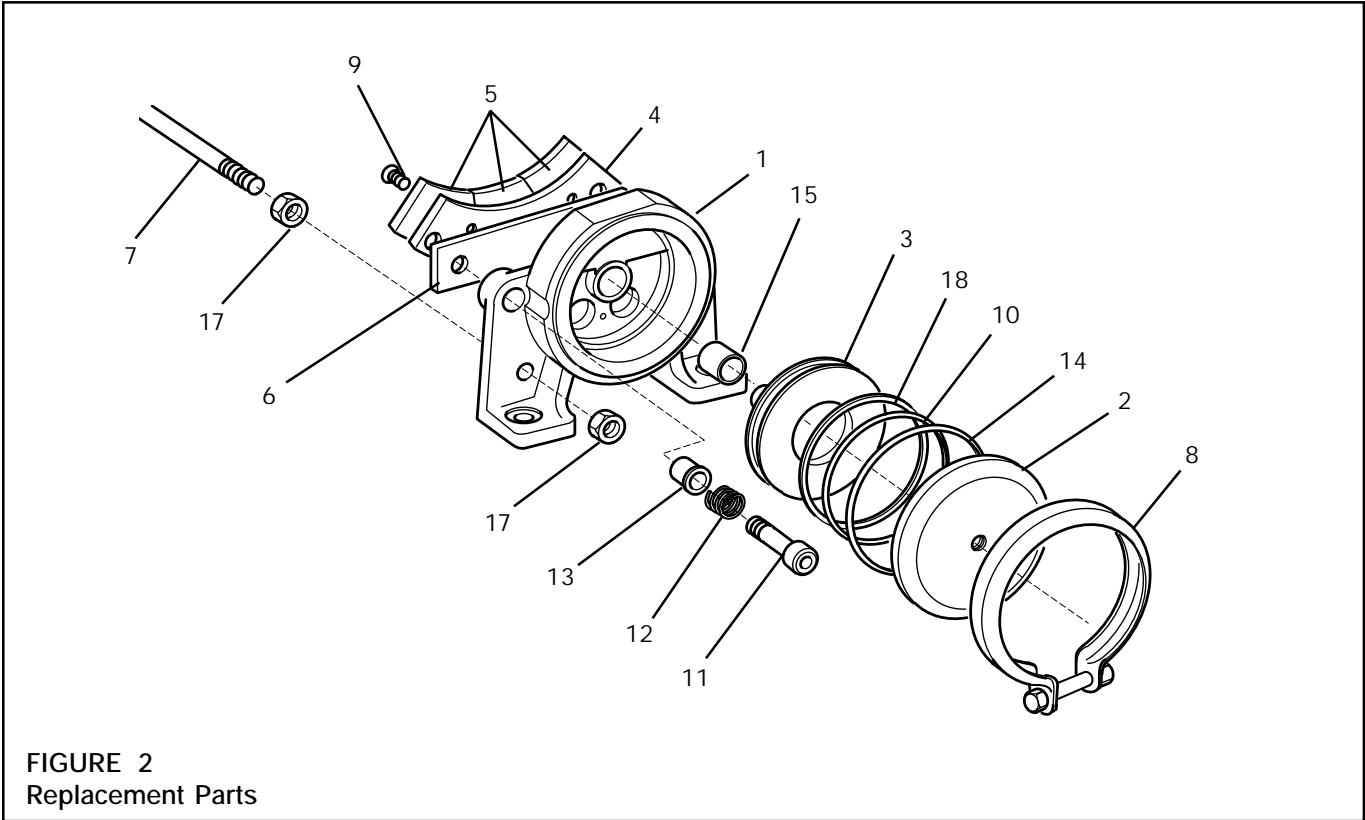

ITEM	DESCRIPTION	QTY
1	Cylinder	2
2	End Cap	2
3	Piston	2
4	Shoe	2
5	Friction Facing	6
6	Shoe Spacer	2
7	Connecting Rod	2
8	Ring Clamp	2
9	Screw	6

ITEM	DESCRIPTION	QTY
10	O-ring Seal	2
11	Screw	4
12	Compression Spring	4
13	Sleeve Bearing	4
14	O-ring Seal	2
15	Sleeve Bearing	2
17	Nut	8
18	Back-Up Seal	2

WARRANTIES

Warranties

Nexen warrants that the Products will be free from any defects in material or workmanship for a period of 12 months from the date of shipment. NEXEN MAKES NO OTHER WARRANTY, EXPRESS OR IMPLIED, AND ALL IMPLIED WARRANTIES, INCLUDING WITHOUT LIMITATION, IMPLIED WARRANTIES OF MERCHANTABILITY AND FITNESS FOR A PARTICULAR PURPOSE ARE HEREBY DISCLAIMED. This warranty applies only if (a) the Product has been installed, used and maintained in accordance with any applicable Nexen installation or maintenance manual for the Product; (b) the alleged defect is not attributable to normal wear and tear; (c) the Product has not been altered, misused or used for purposes other than those for which it was intended; and (d) Buyer has given written notice of the alleged defect to Nexen, and delivered the allegedly defective Product to Nexen, within one year of the date of shipment.

Exclusive Remedy

The exclusive remedy of the Buyer for any breach of the warranties set out above will be, at the sole discretion of Nexen, a repair or replacement with new, serviceably used or reconditioned Product, or issuance of credit in the amount of the purchase price paid to Nexen by the Buyer for the Products.

Limitation of Nexen's Liability

TO THE EXTENT PERMITTED BY LAW NEXEN SHALL HAVE NO LIABILITY TO BUYER OR ANY OTHER PERSON FOR INCIDENTAL DAMAGES, SPECIAL DAMAGES, CONSEQUENTIAL DAMAGES OR OTHER DAMAGES OF ANY KIND OR NATURE WHATSOEVER, WHETHER ARISING OUT OF BREACH OF WARRANTY OR OTHER BREACH OF CONTRACT, NEGLIGENCE OR OTHER TORT, OR OTHERWISE, EVEN IF NEXEN SHALL HAVE BEEN ADVISED OF THE POSSIBILITY OR LIKELIHOOD OF SUCH POTENTIAL LOSS OR DAMAGE. For all of the purposes hereof, the term "consequential damages" shall include lost profits, penalties, delay images, liquidated damages or other damages and liabilities which Buyer shall be obligated to pay or which Buyer may incur based upon, related to or arising out of its contracts with its customers or other third parties. In no event shall Nexen be liable for any amount of damages in excess of amounts paid by Buyer for Products or services as to which a breach of contract has been determined to exist. The parties expressly agree that the price for the Products and the services was determined in consideration of the limitation on damages set forth herein and such limitation has been specifically bargained for and constitutes an agreed allocation of risk which shall survive the determination of any court of competent jurisdiction that any remedy herein fails of its essential purpose.

Limitation of Damages

In no event shall Nexen be liable for any consequential, indirect, incidental, or special damages of any nature whatsoever, including without limitation, lost profits arising from the sale or use of the Products.

Warranty Claim Procedures

To make a claim under this warranty, the claimant must give written notice of the alleged defect to whom the Product was purchased from and deliver the Product to same within one year of the date on which the alleged defect first became apparent.

nexen[®]

Nexen Group, Inc.
560 Oak Grove Parkway
Vadnais Heights, MN 55127

800.843.7445
Fax: 651.286.1099
www.nexengroup.com

ISO 9001 Certified