

nexen[®]

WEB CONTROL PRODUCTS

User Manual



TC250, TC450, and TC650

In accordance with Nexen's established policy of constant product improvement, the specifications contained in this manual are subject to change without notice. Technical data listed in this manual are based on the latest information available at the time of printing and are also subject to change without notice.

Technical Support:
800-843-7445
(651) 484-5900

www.nexengroup.com



WARNING

Read this manual carefully before installation and operation.

Follow Nexen's instructions and integrate this unit into your system with care.

This unit should be installed, operated and maintained by qualified personnel ONLY.

Improper installation can damage your system or cause injury or death.

Comply with all applicable codes.

Nexen Group, Inc.
560 Oak Grove Parkway
Vadnais Heights, Minnesota 55127

TABLE OF CONTENTS

Introduction ----- 1

Controller Operation ----- 2

Installation ----- 3

Control Panels ----- 4

Electrical Connections ----- 8

Configuration ----- 9

Calibration ----- 12

Test Run ----- 15

Maintenance and Testing ----- 18

Troubleshooting ----- 21

Replacement Parts ----- 25

Tension Sensor Specifications ----- 25

Warranties ----- 26

INTRODUCTION

Read this manual carefully, making full use of its explanations and instructions. The “Know How” of safe, continuous, trouble-free operation depends on the degree of your understanding of the system and your willingness to keep all components in proper operating condition. Pay particular attention to all NOTES, CAUTIONS, and WARNINGS to avoid the risk of personal injury or property damage. It is important to understand that these NOTES, CAUTIONS, and WARNINGS are not exhaustive. Nexen cannot possibly know or evaluate all conceivable methods in which service may be performed, or the possible hazardous consequences of each method. Accordingly, anyone who uses a procedure that is not recommended by Nexen must first satisfy themselves that neither their safety or the safety of the product will be jeopardized by the service method selected.

The 50 Series Tension Controllers use digital logic to maintain constant tension. Digital logic is used, rather than the more conventional analog, to allow trim adjustment of many control factors.

These Controllers receive an input signal from a tension sensor and compare it with a desired or ‘set’ tension level. The difference between the sensed and set signals is called deviation. These controllers reduce the deviation to zero by increasing or decreasing their output signal.

The sensed input signal is generated by two Nexen-Nireco MB Tension Sensors. Sensing narrow webs, or wire may be done with one Nexen-Nireco Tension Sensor. Two Sensors are normally used to provide sensing at both ends of a sensor roll. This eliminates any error caused by a difference in tension from one side of the web to the other.

The output signal of the tension control depends on the model number. TC250 has a 4–20mA output. This signal is used with the Nexen-Nireco Electro-Pneumatic Converter. It varies its output air pressure in direct relation to the variable input signal from the TC250. This output air pressure can be used to actuate a pneumatic clutch, brake, or motor.

Output from TC650 is 24VDC (0–6A). This signal is compatible with 24V electro-magnetic clutches, and brakes.

TC450 provides a 0–10VDC output signal to interface with variable speed motors.

CONTROLLER OPERATION

Automatic control operation can be broken down into three parts (See Fig. 1).

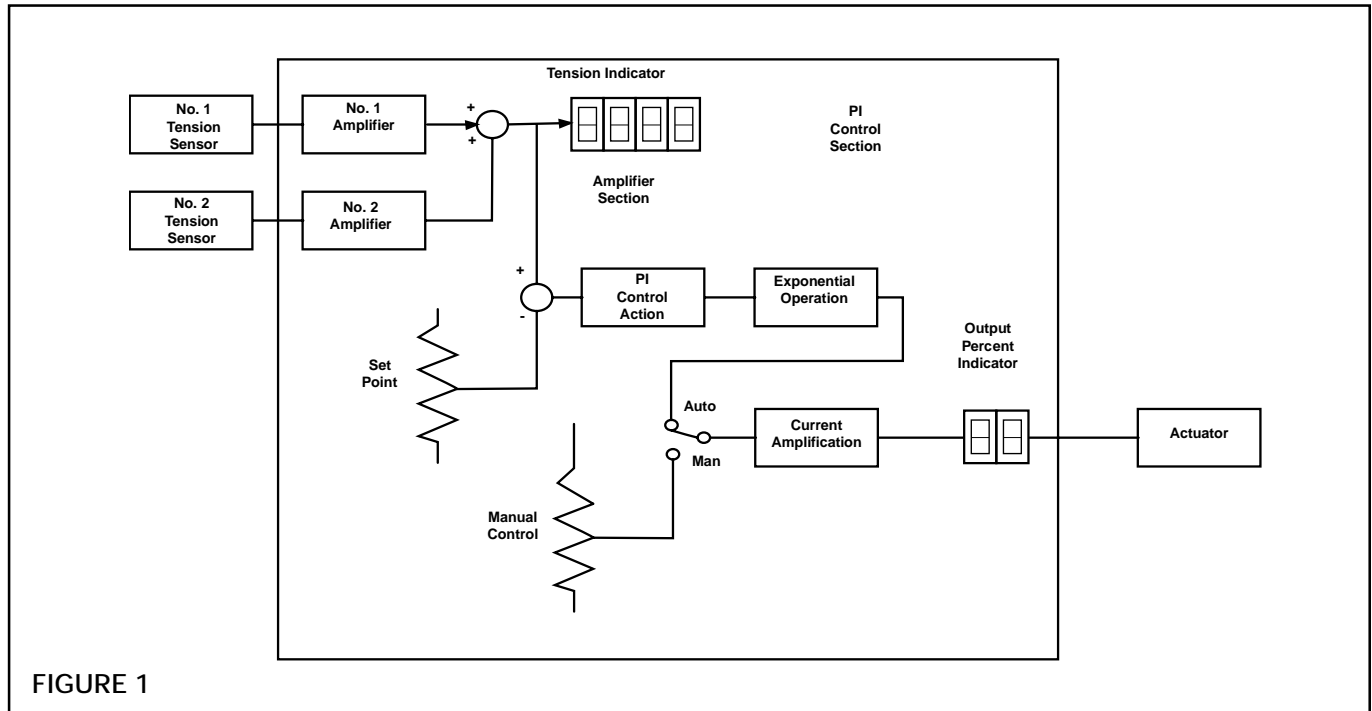

FIGURE 1

THE SIGNAL ADDER SECTION

The signal adder section receives the input signal from each MB Tension Sensor. These signals are 0–400 mV. Each signal is amplified, and the amplified signals are added. The added signal (0–10VDC) is displayed at the tension indicator on the front panel of the controller, as a total tension reading. The tension being sensed by either sensor also may be indicated on this indicator by using the selector switch located inside the controller door.

The added signal is then compared to the 'Target' value, which is set with the Set Point Pot located on the front panel of the controller. Any difference (deviation) between the added signal and set point is transmitted to the logic section.

THE LOGIC SECTION

The logic section drives the deviation to zero by performing the following actions:

1. Proportional (P) control prevents overshooting when the error is removed by integral control.
2. Integral (I) control determines if there is a deviation, and acts to increase or decrease the output, to correct the deviation.
3. For use with winding or unwinding controls, there is also a Derivative (D) control available. This maintains a constant loop gain as the wind or unwind roll constantly changes diameter.
4. Inertia compensation also can be programmed in for acceleration, deceleration, or both.
5. Taper Tension control also can be programmed, in both forward and reverse modes; and based upon internal calculations, or an external roll diameter signal.
6. An initial output during acceleration, can be set and timed. This 'Start' signal can be a fixed value, or vary as the roll diameter changes. The 'Start' function can be timed to last up to ten seconds after the machine starts.
7. For unwinding application there is also a 'Stop' function, which allows the output to be increased during a machine stop, to counteract roll inertia and prevent run-on, slack web, or web spillage. The 'Stop' function also can be timed for up to ten seconds.

THE OUTPUT AMPLIFIER

The output amplifier receives the signal from the PI section and amplifies it to the correct output signal level. This output level is shown on the indicator located on the front panel.

INSTALLATION



WARNING

This unit is an electronic instrument and should not be mounted where it will be subjected to shock, vibration, excessive heat, or moisture.

The controller can be shelf or floor mounted using the mounting feet installed on the controller.

1. For wall mounting, remove mounting feet from the controller base, then remove the rubber pads, and reinstall the mounting feet in the rear mounting holes on the sides of the controller.
2. For panel mounting, the same feet may be used as above, only installed in the forward mounting holes on the sides of the controller.

NOTE: The controller may be mounted at any angle.

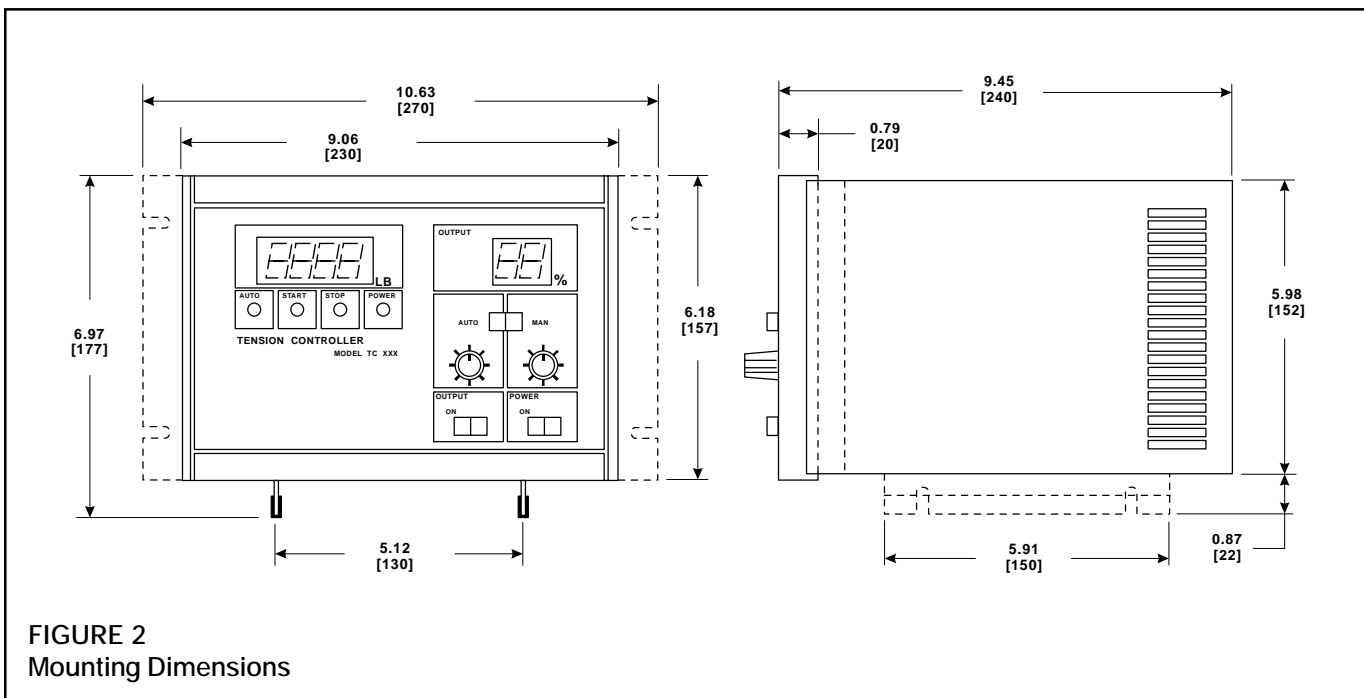

CONTROL PANELS

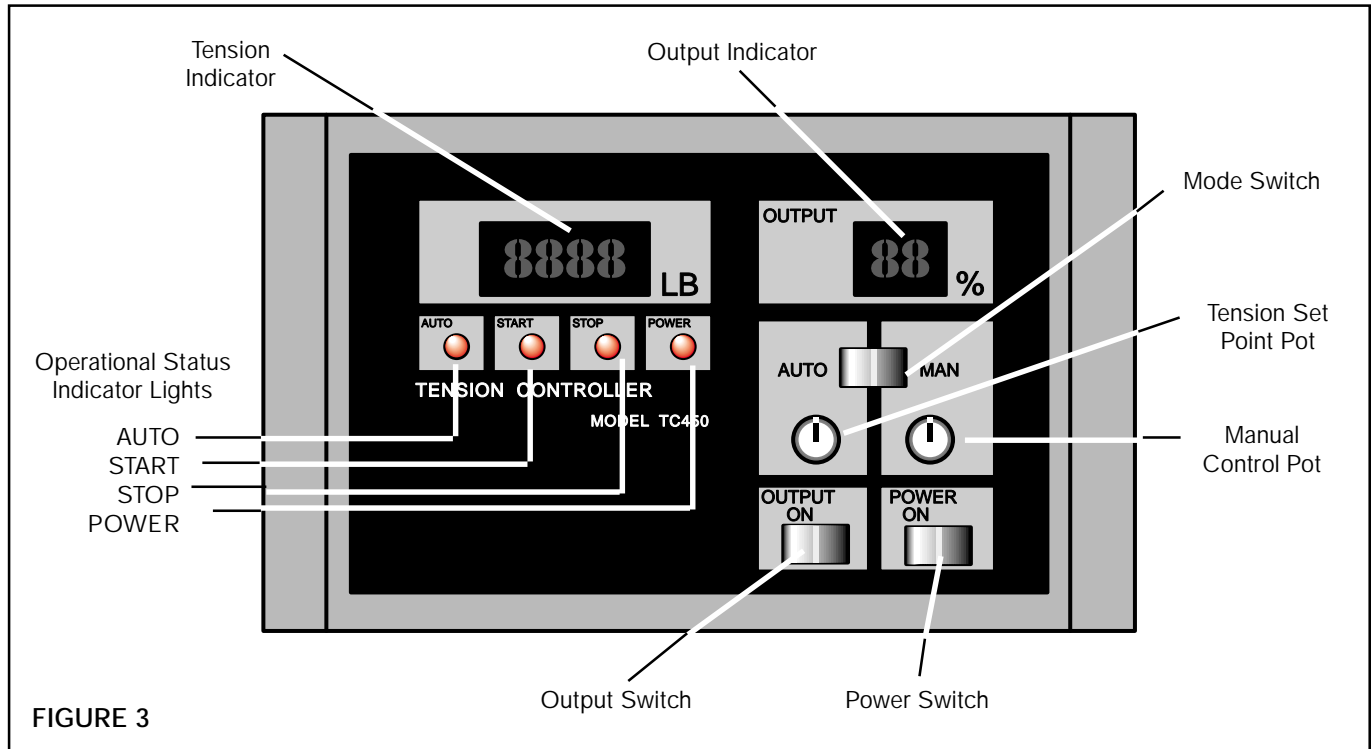

FIGURE 3

FRONT PANEL (See Fig. 3)

1. **TENSION INDICATOR** (7 segments, 4 digits, with decimal)

Displays actual web tension in pounds of total tension.

2. **OUTPUT INDICATOR** (7 segments, 2 digits)

Displays controller output, as a percentage of total capacity. Reads 0 to 99 percent. No display when Output Switch is set to "OFF".

3. **OPERATIONAL STATUS INDICATOR LAMPS**

Shows operation status of the controller as follows:

- a. **POWER**
Lights when the Power Switch is ON.

NOTE: The following lamps are used only when the 'MODE' Switch located on the front panel is set to 'AUTO'. When the switch is set to 'MAN', all lamps except the POWER lamp go off.

- b. **AUTO**
Shows automatic operation status. The output is being varied to maintain a constant tension value at the set point.
- c. **START**
Shows ready to start status. A stall torque output is being delivered before the automatic operation begins.
- d. **STOP**
Indicates stop status. An increased "STOP" level output is being delivered, to eliminate slackening of web tension when the machine is stopped.

5. **MODE SWITCH**
Selects Automatic or Manual Operation Mode.

6. **TENSION SET POINT POT**
Used when the Mode Switch is set to 'AUTO'. Sets the desired tension value. One graduation on the pot equals 10 percent of the full scale value of the Tension Indicator.

7. MANUAL CONTROL POT

Sets output manually during operation in the Manual Mode. It is used for setting the 'START' output value during operation in the Automatic Mode.

8. OUTPUT SWITCH

Allows the output to be totally disconnected from

the controlled unit, when set to the 'OFF' position. Normally set to the 'ON' position.

9. POWER SWITCH

Controls power to the Tension Controller. Power Lamp illuminates when the Power Switch is set to the 'ON' position.

INSIDE CONTROL PANEL (Side Face) (See Fig. 4)

Left Hand Side

1. **DEC. T**
 DECEleration Timer (0 to 10 seconds).
2. **DEC. L**
 Inertia compensation Level for DECEleration.
3. **ACE. T**
 ACCeleration Timer (0 to 10 seconds).
4. **ACE. L**
 Inertia compensation Level for ACCeleration.
5. **DDW**
 Broken line deviation width (0 to 10% of full scale).
6. **DDG**
 Broken line gain (variable from x 0 to x 1.0).
7. **PAS. T**
 Not used.
8. **PAS. L**
 Not used.
9. **STOP/MIN**
 Sets MINIMUM 'STOP' output value (0 to 30%). Prevent Stop output from dropping too low.

Right Hand Side

10. **NO. 1 ZERO**
 Calibration pot for tension sensor.
11. **NO. 2 ZERO**
 Calibration pot for tension sensor.
12. **NO. 1 SPAN**
 Calibration pot for tension sensor.
13. **NO. 2 SPAN**
 Calibration pot for tension sensor.
14. **READ OUT SELECTOR**
 Selector switch to indicate the tension value at No. 1 Sensor, No. 2 Sensor, or the total tension on the tension indicator.

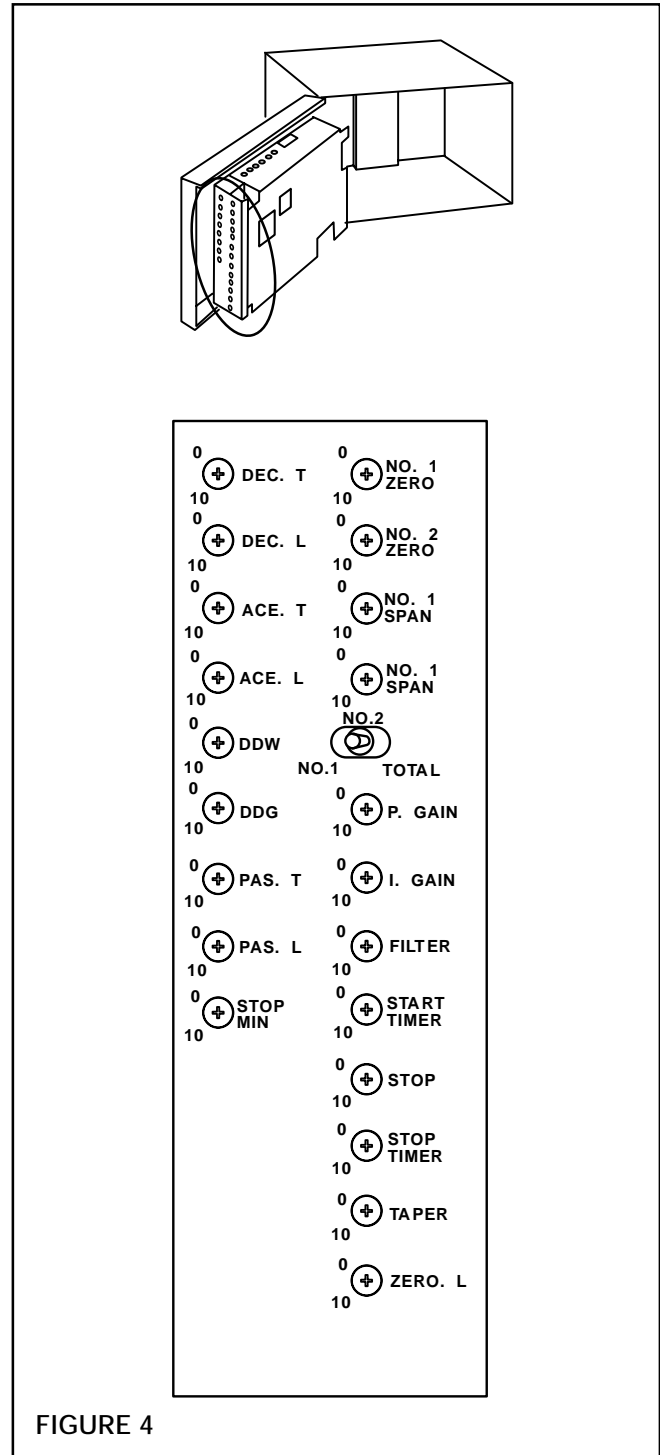
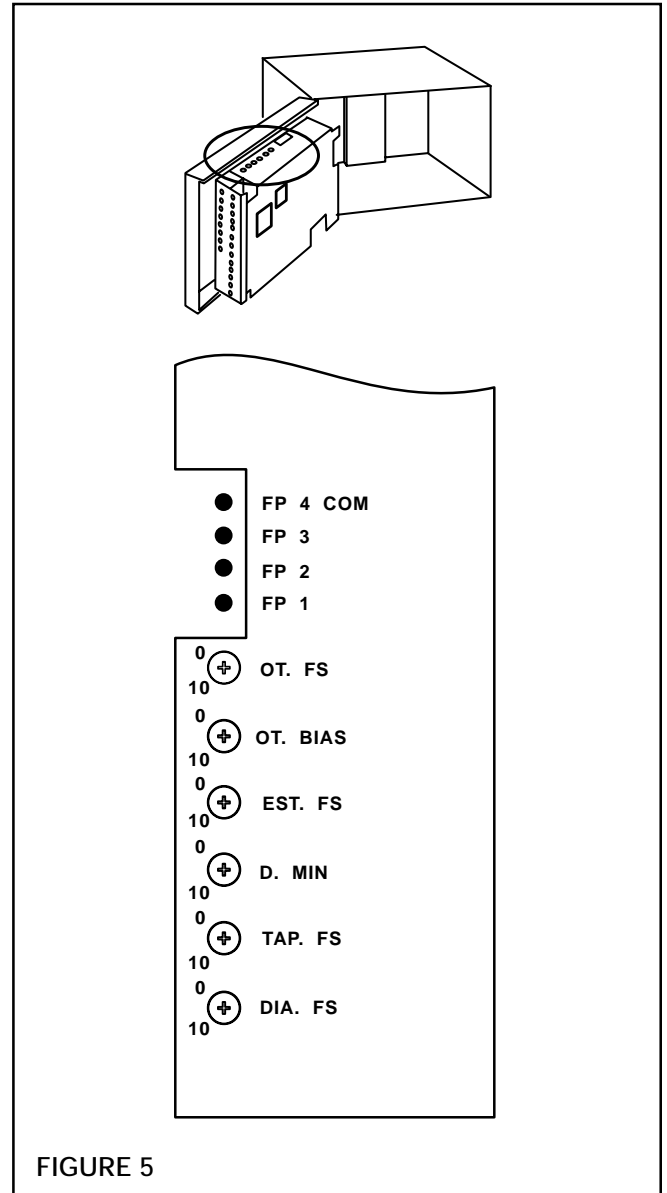

FIGURE 4

- | | |
|--|---|
| <p>15. P. GAIN
 Proportional GAIN Pot.</p> <p>16. I. GAIN
 Integral GAIN Pot.</p> <p>17. FILTER
 Filter</p> <p>18. START/TIMER
 START/TIMER Pot, times duration of 'START' cycle.</p> | <p>19. STOP
 STOP Pot. controls output during 'STOP' cycle.</p> <p>20. STOP/TIMER
 Sets duration of the 'STOP' cycle (0 to 10 seconds).</p> <p>21. TAPER
 Sets taper rate for taper tension control.</p> <p>22. ZERO. L
 ZERO-tension Level (0 to 30% of full scale).</p> |
|--|---|

INSIDE CONTROL PANEL (Top Face) (See Fig. 5)

1. **FP 1, 2, 3, & 4**
 Check Pins
2. **OT. FS**
 Not used
3. **OT. BIAS**
 Not used
4. **EST. FS**
 External Signal Trim Pot, (Full Scale), used to trim the signal from an external analog diameter source.
5. **D. MIN**
MINimum Diameter pot, used to trim the signal from an external analog diameter source.
6. **TAP. FS**
TAPer circuit trim pot (Full Scale), used to trim the signal from an external analog diameter source.
7. **DIA. FS**
DIAmeter trim pot (Full Scale), used to trim the signal from an external analog diameter source.



CONFIGURATION SWITCHES (Main PC Board "A")
 (See Fig. 6)

1. SW1
 Rotary switch for setting the second digit of the Full Scale Range of the Tension Indicator.
2. SW2
 Rotary switch for setting the first digit of the Full Scale Range of the Tension Indicator.
3. SW3-1 and -2
 Dip switches used to set the decimal point position on the Tension Indicator.
4. SW3-3 and -4
 Dip switches used to define the taper tension mode.
5. SW3-5
 Dip switch used to determine controller correction logic
6. SW3-6
 Dip switch used to select use of an external analog diameter signal.
7. SW3-7
 Dip switch activates Zero Tension circuitry (web break detection).
8. SW3-8
 Dip Switch determines control basis for Start Level output.
9. SW4-1
 Sip switch enables/disables derivation calculation in the control logic.
10. SW4-2
 Dip switch selects either internal or external origin for Set Point Signal.
11. SW4-3, -4, -5, & -6
 Dip switches to determine the use of inertia compensation during acceleration/deceleration, and the basis for the correction.
12. SW5-1
 Dip switch allows instant transition to Stop Level output or a gradual transition.
13. Sw5-2, -3, & -4
 Dip switches which are not used. Must always be set to "OFF".

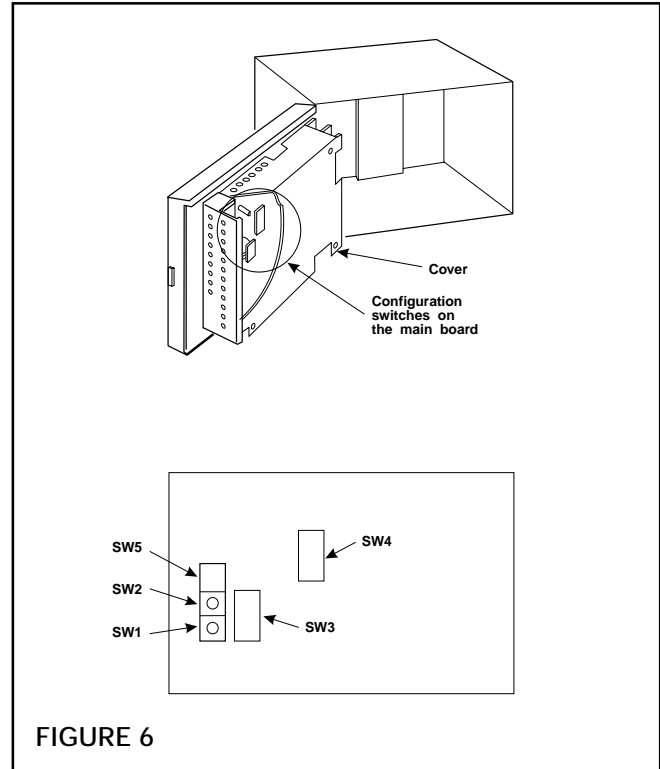
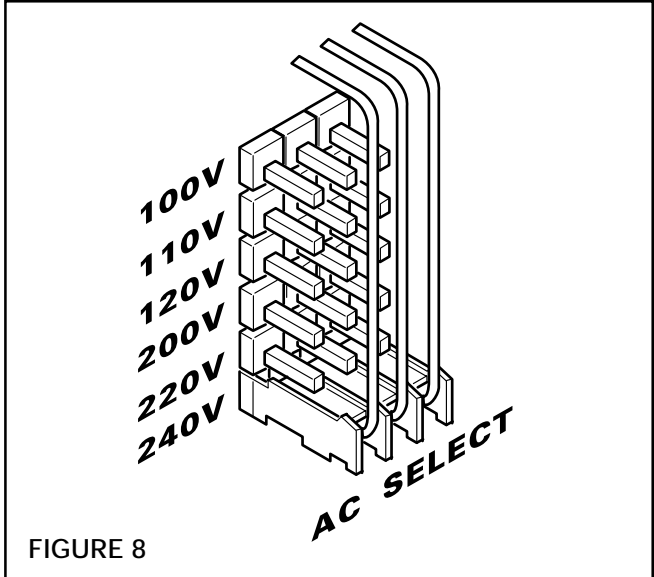
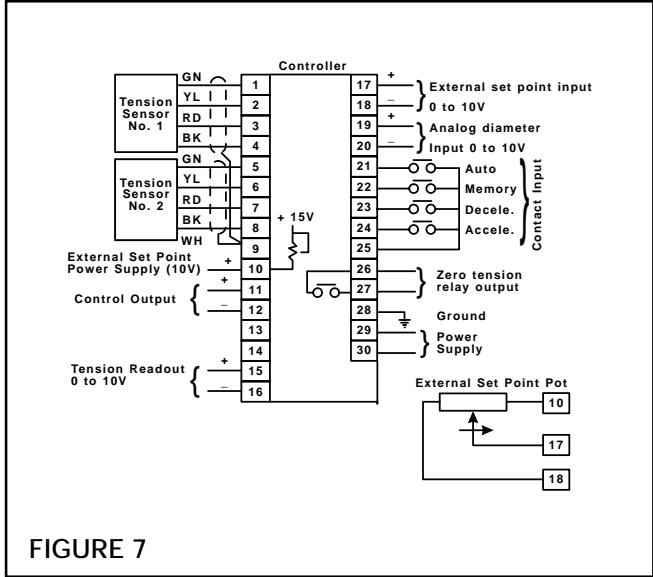

FIGURE 6

ELECTRICAL CONNECTIONS



NOTE: Always set the Power Supply Selector to the power supply voltage used before making electrical connections. (Power supply is factory set to 240VAC.) Do not use a power voltage that is greater than plus or minus 10%. (See Fig. 8)

CAUTION

The sensor signal line and the control signal line of the Controller and related equipment use weak electrical signals. To prevent signal interference and cross-talk, arrange wiring as far from strong electrical circuits as possible, or shield the signal lines, or run signal in conduit.

Use crimp style terminals with insulation for connecting wires to the terminal block. Use 3mm screws for external connections.

1. Use cable provided with the MB Tension Sensor to connect sensors to the Controller. (See Fig. 7).

NOTE: Reverse GREEN and YELLOW wire when using MB-11, and MB-25 with reverse wrap. For single sensor operation, connect as normal for sensor No. 1, and provide a jumper wire to short terminals No. 1, and No. 5.

2. Wire External Set Point Pot (if used) using Terminals 10, 17, and 18 (See Fig. 7).

3. Control Output at Terminals 11, and 12 varies according to the model: TC-250 output is 4–20 milliamps, TC-450 output is 0–10 VDC, and TC-650 output is 0–24VDC.
4. The Tension Readout Signal varies with the Tension Indicator reading, where 0 to 10VDC is equal to 0 to Maximum full scale readout.
5. If an external analog signal is used, it is wired to Terminals 21, and 25.
6. External contacts wired to Terminals 21 through 25 must be electrically isolated or use dry contacts to prevent ground loops.
 - a. The Auto Relay closes to begin the Start Time. When the Start Time elapses, the Controller begins Automatic Control. When the Auto Relay opens, the Automatic Control ends, and the Stop Time begins. After the Stop Time elapses, the Controller returns to the Start output, and is ready to Restart.
 - b. The Memory Relay causes the memory to store the output value present at the time the relay closes. This relay should be timed to make contact just as the Auto Relay is opened and must remain open until after the Controller returns to Start Status.
 - c. The Deceleration Relay enables the deceleration circuitry. The deceleration circuit remains enabled as long as the Deceleration Relay is held closed.

- d. The Acceleration Relay enables the acceleration circuitry. The acceleration circuit remains enabled as long as the Acceleration Relay is held closed.
6. The Zero Tension Relay is rated at 30VDC, 0.2A; or 250VAC, 0.2A.

7. Connect AC Power at 100, 110, 120, 200, 220, or 240VAC, either 50 or 60 Hertz, to Terminals 29, and 30, with Earth Ground to Terminal 28.

WARNING

Jumper wire must be properly positioned for power supplied.

CONFIGURATION

SET FULL SCALE VALUE FOR THE SYSTEM (SW3-1 and -2)

1. Using Switches SW3-1, and SW3-2, set decimal position(See Table 1).
2. Using Switch SW2, set the first significant digit of the Full Scale Value (Any value 1through 9) .
3. Using Switch SW1, set the second significant digit of the Full Scale Value (Any value 1 through 9) .

NOTE: Zero adjustment and span adjustment cannot be made if a full scale value is set that deviates greatly from the ratings of the tension sensors. Set the full scale at, or around the rated value of the tension sensor.

EXAMPLE 1:

Set the switches as follows if the full scale is set to 25.0 pounds.



- SW2: Set to 2.
- SW1: Set to 5.
- SW3-1: Set to OFF
- SW3-2: Set to ON

EXAMPLE 2:

Set the switches as follows if the full scale is set to 120 pounds.

- SW2: Set to 1
- SW1: Set to 2
- SW3-1: Set to ON
- SW3-2: Set to OFF

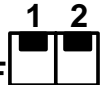
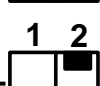
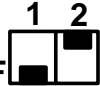
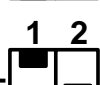
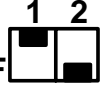
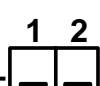
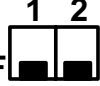
TABLE 1

FULL SCALE	SW3-1, 2
0.10 to 9.90	ON  OFF 
1.0 to 99.0	ON  OFF 
10 to 990	ON  OFF 
100 to 1000	ON  OFF 

SET TAPER TENSION MODE (See Table 2)

1. Select desired mode from the following:

a. Internal Forward Mode

Used to apply a taper tension signal to a winding clutch. Taper rate is based upon internal calculations, and the position of the Taper Tension Pot. This is the standard Taper Tension Mode. When Taper Tension is not desired, use the Internal Forward Mode, and set the Taper Pot to "0".







b. Internal Reverse Mode

Used to apply a reversed taper signal to an unwind brake on a single zone machine, such as a slitter. Taper rate is based upon internal calculations and the position of the Taper Tension Pot.

c. Forward/Diameter Mode

Used to apply a taper tension signal to a winding clutch. Taper rate is based upon an

TABLE 2

SW3	SW3-3	SW3-4	
ON  OFF 	OFF	OFF	Internal Forward
ON  OFF 	ON	OFF	Internal Reverse
ON  OFF 	OFF	ON	Forward Diameter

external analog roll diameter signal, and the position of the Taper Tension Pot.

d. In all three Modes, the "0" position on the Taper Pot yields no taper, taper rate increases as the pot is rotated toward "10".

2. Set Switches SW3-3, and SW3-4 to conform to the Taper Mode selected above.

SET CONTROL DIRECTION (SW3-5)

Forward Control is the "Normal" direction; when tension is too low the output increases, and vice versa. Reverse Control is used to control devices (motor or clutch) that are located before the web reaches the sensors. With Reverse Control, the output increases when tension is too high, and decreases when the tension is too low.

Set Control Direction with Switch SW3-5, "ON" for Forward Control, and "OFF" for Reverse Control

SET EXTERNAL ANALOG DIAMETER INPUT (SW3-6)

An external analog diameter signal, in the range of 0 to 10VDC, can be used for Taper Tension or Stop Cycle controls.

If an external diameter input is to be used, set Switch "SW3-6" to "ON". If no external diameter signal is to be used, set the Switch to "OFF".

SET ZERO TENSION RELAY SWITCH (SW3-7)

A normally open relay at Terminals 26 and 27 closes when tension falls below the value set with the Zero Tension Pot.

Set Switch "SW3-7" to "ON" when the Zero Tension Relay is needed, after the zeroing phase of load cell calibration has been completed. Set the Switch to "OFF" if the Zero Tension Relay is not needed.

Switch "SW3-7" controls this relay. Set it to "OFF" if the Zero Tension Relay is not needed, or when performing the Zero Calibration during the load cell calibration procedure.



SET START LEVEL MODE (SW3-8)

The output delivered during the Start phase of the Automatic Control Mode is called the Start Level. Start Level can be controlled in one of three ways.

In standard configuration, the Start Level is set with the Manual Pot on the front panel. The Start Level can be adjusted any time the Controller is in Start Mode and the Start Status lamp is "ON".

The Start Level can also be varied based upon an input from an external analog diameter signal (see "Set External Analog Diameter Input" above). In this mode the Start Level varies as the roll diameter changes, this is called the Variable Mode. The Manual Pot is used to set the Start Level output at the maximum roll diameter, and the external analog diameter signal is used to decrease the output at smaller diameters.

The Start Level can also be based upon the output at the end of the previous Automatic operation. This is called the Memory Mode. The output at the time the Memory Relay is closed across Terminals **22** and **25** is held in memory as long as contact is maintained. This memorized value is multiplied by the setting on the Manual Pot to determine the Start Level. The "0" to "10" of the pot is equivalent to a "0" to "1" multiplier. Thus, if the desired Start Level is 50 percent of the previous output, set the Manual Pot at position "5".

To use the Variable Mode, set Switch "SW3-8" to "ON". Set the Switch to "OFF" for Memory Mode, or for standard configuration.

ENABLE CONSTANT LOOP GAIN (SW4-1)

A derivative logic circuit is provided to maintain a constant gain in the control loop as the roll diameter changes on winding or unwinding operations. This circuit is not need, and can be counterproductive, on internal drives, such as nip rolls or s-wrap drives.

To enable the derivative logic circuit, set Switch "SW4-1" to "ON". To disable the circuit, set the Switch to "OFF".

SET POINT SELECTION (SW4-2)

The Set Point, or desired tension level, is normally set with the Auto Set Point Pot on the front panel. The Set Point can also be set with a remote signal received at Terminals **17** and **18**.

To use the Auto Set Point Pot, set Switch SW4-2 to "ON". To follow a remote signal, set the Switch to "OFF".

INERTIA COMPENSATION MODE (SW4-3,-4,-5, and -6) (Unwind Brake Control)

During acceleration and deceleration of high speed machines, tension in the web will often momentarily decrease as the machine transitions from acceleration to steady state speed, or from steady state speed to deceleration.

The controller provides an inertia compensation circuit to correct this problem. The inertia compensation circuit increases the Tension Set Point during the final phase of acceleration and during the initial phase of deceleration. This artificially raised set point causes the output to increase during the transition phase, thus eliminating the drop off in tension.

There are three methods of controlling the inertia compensation circuit:

1. The Set Point Method is simplest, and requires no external diameter signal. The Set Point can be increased between 0 and 50 percent with the "ACE. L" pot during acceleration, or the "DEC. L" pot during deceleration. This increased Set Point value continues for a period of time as determined by the "ACE. T" pot for acceleration or the "DEC. T" pot for deceleration, both pots have a time duration of 0 to 10 seconds. This timing is initiated by a momentary contact closure at Terminals **24** and **25** for acceleration, and Terminals **23** and **25** for deceleration.
2. The Set Point/Diameter Method is also based upon the Set Point value but is modulated as the roll changes in diameter. The "ACE. L" and "DEC. L" pots set the maximum increase value during acceleration and deceleration, this amount of

increase is only available at Full Roll Diameter. As the roll diameter decreases, the amount of Set Point increase also decreases, in direct proportion. The time duration of the increased Set Point value is controlled by the relay that is applied to Terminals 24 and 25 for acceleration, and Terminals 23 and 25 for deceleration.

3. There is also the Output/Diameter Method which acts directly upon the controller output. Here the output can be increased by as much as 100 percent at the Full Roll Diameter tapering off to no increase at the core. The percent of increase available at the Full Roll Diameter is controlled with the "ACE. L" pot for acceleration, and the "DEC. L" pot for deceleration.

Set the desired type of inertia compensation for acceleration with Switches SW4-3 and SW4-4. Set the desired type of inertia compensation for deceleration with Switches SW4-5 and SW4-6. Refer to Table 3 for Switch settings.

TABLE 3

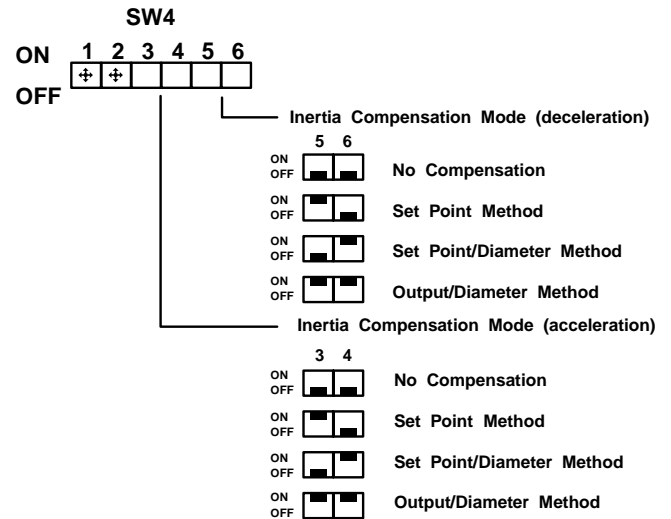

STOP LEVEL FILTER (SW5-1) (Unwind Brake Control)

At times it is desirable to increase the output of the controller from normal to the higher level dictated by the Stop Pot, on a filtered curve rather than an immediate change. On slower machines this can prevent over tensioning during the transition from steady state running to the Stop Level output.

Switch SW5-1 to "ON". For normal, immediate, increase to the Stop level, set Switch SW5-1 to "OFF".

NOTE: Switches SW5-2, SW5-3, and SW5-4 must always be set to "OFF".

To achieve this filtered increase to the Stop level, set

CALIBRATION

The number of items to be calibrated depends upon the configuration of the controller. The minimum calibration, necessary for all configurations, requires setting the Full Scale Tension Value of the controller, Zero Adjustment of the Tension Sensors, and Span Adjustment of the Tension Sensors. Other calibration steps must be performed as necessitated by the use of various optional functions selected during configuration of the controller.

FULL SCALE TENSION SETTING

The position of the decimal point and full scale value of the Tension Indicator (also the whole system) is set with Switches SW1, SW2, SW3-1, and SW3-2 (See CALIBRATION, Set Full Scale Value for the System).

NOTE: Adjustment of Zero and Span can be impossible if the Full Scale Value of the Tension Indicator is greatly different from the tension measurement capacity of the Tension Sensors. Calculate the maximum tension measurement capacity of the Tension Sensors, based on the web angle over the sensing roller and the force capacity (See TENSION SENSOR SPECIFICATIONS) for the model Tension Sensor being used.

ZERO ADJUSTMENT (See Fig. 9)

1. Set Power Switch to "ON".
2. Make sure Sensor Roll is mounted to "MB" Sensors as described in "MB Sensor Manual, L-20127.
3. Make sure the web has been removed, and no other objects are sitting or leaning on Sensor Roll.
4. Set Switch SW3-7 to "OFF".
5. Set Selector Switch to "1".
6. Adjust "No. 1 Zero" pot until Tension Indicator displays "0".
7. Set Selector Switch to "2".
8. Adjust "No. 2 Zero" pot until Tension Indicator displays "0".
9. Set Selector Switch to "TOTAL", Tension Indicator should still display "0".
10. Set Switch SW3-7 to "ON" if Zero Tension Circuit is needed.

NOTE: Tension Indicator will not display negative numbers, therefore be careful when adjusting Zero Pot to prevent overshooting.

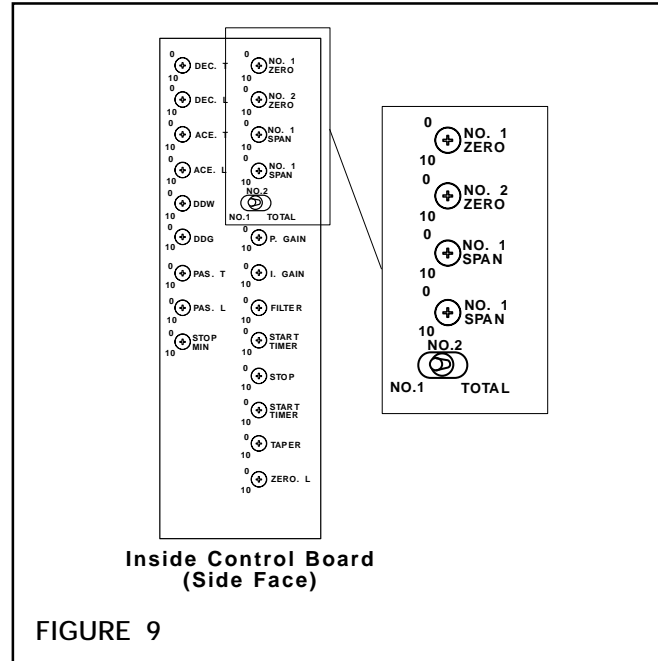

SPAN ADJUSTMENT

1. Thread a rope or narrow web over the Sensor Roll in the normal web path. Secure one end of the rope. Insure that the rope is at the center of the Sensor roll. Hang a known weight (within the Full Scale range of the system) on the other end of the rope (See Fig. 10).
2. Set Selector Switch to "No. 1".
3. Adjust "No. 1 Span" pot until the Tension Indicator displays one half the known weight applied to the rope.
4. Set the Selector Switch to "No. 2".
5. Adjust "No. 2 Span" pot until the Tension Indicator displays one half the known weight applied to the rope.

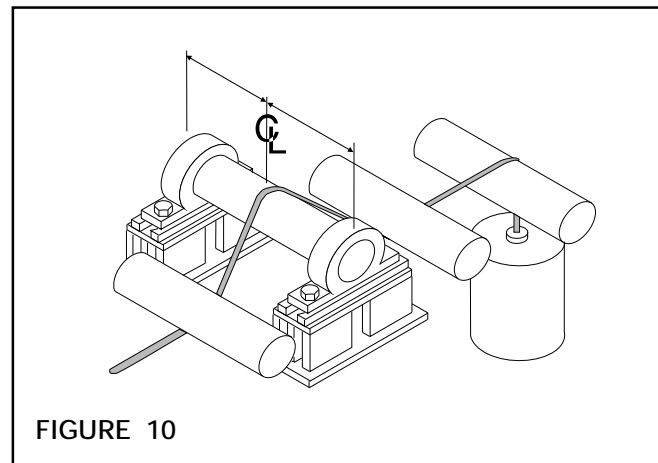

CALIBRATION USING ONLY ONE SENSOR

1. Make sure that Sensor is wired correctly (See **ELECTRICAL CONNECTIONS, step 3**), and that the Jumper Wire is placed between Terminals 1 and 5.
2. Perform Zero Adjustment (See **CALIBRATION, Zero Adjustment**) for "No. 1 Zero". It is not necessary to perform "No. 2 Zero".
3. Perform Span Adjustment (See **CALIBRATION, Span Adjustment, Step 1**).
4. Set Selector Switch to "TOTAL".
5. Adjust "No. 1 Span" pot until the Tension Indicator displays the known weight.

NOTE: It is not necessary to perform "No. 2 Span".

NOTE: This completes the basic calibration of the Tension Controller. The following calibration techniques are necessary only if special functions have been selected during configuration. All of these calibration techniques are performed using the Pots, and Check Pins (CP) located on the Top Face of the Inside Control Panel (See **CONTROL PANELS, Inside Control Panel, Fig. 5**).

CALIBRATION OF THE ANALOG DIAMETER INPUT

NOTE: This Calibration must be performed if an Analog Diameter Input signal is being applied at Terminals 19 and 20

1. Set Switch **SW3-6** to "ON", to enable the analog input circuitry.
2. Set Analog Diameter Input Signal at the maximum diameter value (approximately 10V).
3. Adjust "**DIA.FS**" pot so that voltage measured between "**CP2**" and "**CP4**" is 5VDC (See **MAINTENANCE AND TESTING, Testing**, for location of "**CP2**" through "**CP4**" on the Display Board).
4. Set Analog Diameter Input Signal to the core diameter value.
5. Adjust "**D. MIN**" pot so that voltage measured between "**CP3**" and "**CP4**" is 0VDC.
6. Set Analog Diameter Input Signal at the maximum diameter value.
7. Adjust "**TAP. FS**" pot so that voltage measured between "**CP3**" and "**CP4**" is 5VDC.

CALIBRATION OF THE EXTERNAL SET POINT

NOTE: If an External Set Point signal is being applied to Terminals 17 and 18, the following calibrations must be performed.

1. Set Switch **SW4-2** to "OFF". to enable the external set point circuitry.
2. Set the External Set Point signal to its maximum value (approximately 10VDC).
3. See **MAINTENANCE AND TESTING, Testing**, for location of "**CP1**" and "**CP4**" on the Display Board.
4. Adjust "**EST. FS**" pot so that voltage between "**CP1**" and "**CP4**" is 5VDC.



TEST RUN

After completing the Configuration and Calibration, a Test Run should be performed. Make the Test Run with the lowest tension web to be used in normal operation. The lower the tension in the web, the more sensitive it will be to system stability. If satisfactory control is achieved with a low tension web, there should be no problem with high tension webs.

NOTE: Prior to making the Test Run, check the following:

1. Ensure that no wires, cables, or air lines are in contact with the web, or rotating parts of the machine
2. Check that all rotating parts of the machine move freely, that there is no mechanical binding, or excess rotational friction.
3. Recheck all electrical connections.
4. Make sure Voltage Select Jumper is set to the correct AC supply voltage level (See "Electrical Connections, Fig. 8).
5. If using the TC250 with the EN-40 Electro-Pneumatic Converter, make sure air system is correctly installed (See Manual L-20127)

POWER ON

NOTE: When the Power is "ON", the Tension Indicator on the front panel displays the actual web tension, as measured by the Tension Sensors.

1. When the power is turned "ON", the Automatic or Manual Mode is activated, depending on the position of the Mode Switch.
2. Output Switch "ON". This switch must be turned "ON" to provide an output at the Output Terminals, and to provide a signal to the Output Indicator.
3. In Manual Mode; all Status Lamps except Power Lamp are "OFF". The output of the Controller is varied with the Manual Pot.
4. In Automatic Model; one of the Status Lamps will be "ON", depending on the status of the Auto Relay connected to Terminals 21 and 25 (See **ELECTRICAL CONNECTIONS**, Step 6, a.).

AUTOMATIC MODE, START STATUS

NOTE: If the Controller is in Start Status; the output is the Start Level. The Start Status Lamp comes "ON".

1. In standard configuration, Start Level is controllable with the Manual Pot.
2. The Start Level can be varied in the Variable Mode, based upon an external analog diameter signal.
3. Start Level can also be the memorized previous automatic control level in the Memory Mode.
4. Refer to **CONFIGURATION, Set Start Level Mode**, for Variable or Memory Mode.
5. When the Relay Contacts connected to Terminals 21 and 25 are closed, the time set on the Start Timer begins.

AUTOMATIC MODE, AUTOMATIC STATUS

NOTE: When the Start Time has elapsed, the Automatic Mode will progress into its Automatic Status. The Automatic Status Lamp comes "ON".

1. While the Controller is in Automatic Status, the actual tension in the web, as measured by the Tension Sensors, is constantly compared to the Tension Set Point as defined by the Auto Pot on the front panel.
2. If actual tension is not equal to the Set Point tension, the Controller will vary its output to the clutch, brake, or drive it controls, to cause the actual tension to become equal to the set point.
3. The Set Point tension can be adjusted any time, while controlling in the Automatic Mode, output will change to follow the new set point.

4. Response speed, or sensitivity, of the Controller can be adjusted with the Gain Controls. Gain should always be adjusted while the web is moving at normal processing speeds, as increases in response speed can be accompanied by a decrease in control stability.

Control instability, or hunting, occurs when the output of the Controller will not "settle down", and the reading on the Tension Indicator wanders. Four common causes for hunting are:

- a. Incorrect gain adjustment of the Tension Controller.
- b. Excess brake, clutch, or drive capacity.
- c. Eccentricity of the unwind roll.
- d. Excessive mechanical friction in the machine components.

Decreasing the Proportional Gain adjustment can help with all these problems. With Items **b**, **c**, and **d**, if hunting cannot be eliminated with the gain controls, correction of the mechanical problem is required.

5. Proportional Gain is controlled with the "**P. GAIN**" pot on the side panel. Set the Proportional Gain to position "5" as a starting value. Increase the gain toward "10" if the Controller is reacting too slowly to maintain constant tension. Decrease the gain toward "0" if the controller is overreacting and correcting too fast to maintain stability.
6. Integral Gain is controlled with the "**I. GAIN**" pot on the side panel. Set the Integral Gain to position "5" as a starting value. The "**I. GAIN**" pot is generally set at the same value as the "**P. GAIN**" pot. Response speed is increased by advancing the pot toward "10", and decreased by retarding toward "0".
7. On high speed machines, during the transition from acceleration to steady state running, and from steady state running to deceleration, the inertia of the unwind roll can cause a temporary decrease in tension. Most this problem can be corrected through use of the Inertia Compensation Circuitry (See **CONTROL PANELS, Configuration Switches**).

Any residual instability or tension lag can be corrected with the Deviation Detection Circuit. This circuit senses large scale deviations between actual and set point tension, then increases the correction rate to remove the deviation faster.

8. The magnitude of deviation that will enable the Deviation Detection Circuit is controlled with the "**DDW**" pot on the side panel. The movement of the pot from 0 to 10 varies the trigger point from 0 to 10 percent of Full Scale on the Tension Indicator.

EXAMPLE:

If "**DDW**" is set for "5", a deviation of more than 5 percent of Full Scale between actual and set point tension will activate the Deviation Detection Circuit.

Set the "**DDW**" pot to position "5" as a starting value.

9. The increase in Proportional Gain caused by the activation of the Deviation Detection Circuit is controlled with the "**DDG**" pot.

The starting value for the "**DDG**" pot is 10 (maximum). To set a desired increase rate, set the "**DDG**" pot for the inverse of the desired magnification of the Proportional Gain.

EXAMPLE:

To apply a Proportional Gain that is twice the normal Proportional Gain, whenever the Deviation becomes more than 5 percent of Full Scale.

- a. Set "**DDW**" to graduation "5" (sets the trigger point at 5 percent).
- b. Set "**DDG**" to graduation "5" (the inverse of 2 is 5).

10. The "**Filter**" pot located on the side panel controls minor, low frequency fluctuations in tension which cause constant changes in the Tension Indicator reading. Set the "**Filter**" pot to "5" as a starting level. To increase the suppression of the transient readings, advance the pot toward "10", to increase the Tension Indicator sensitivity, decrease the setting toward "0".



AUTOMATIC MODE, STOP STATUS

When the relay contacts connected to Terminals **21** and **25** are opened, the Controller enters its Stop Status. The Stop Status Lamp comes **"ON"**.

1. The output of the Controller increases to the Stop Level as determined by the "Stop" pot on the side panel. The Stop Level is based upon the output of the Controller at the time the relay contacts are opened. The Stop Pot controls the amount of increased output needed to decelerate the unwind roll to zero speed, without causing slackness in the web tension.
2. The "0" to "10" span of the Stop Pot controls the multiple applied to the output. The multiple varies in a range of 1 times output (at "0"), to 3 times output (at "10"). Set the Stop Pot to decelerate the web smoothly, without losing tension. Too much output increase will raise the tension level above the desired level. A position of "3" (about 1.5 times increase) is a good starting value.
3. The Stop Timer Pot determines the length of time the Stop Level output is applied to the brake. The "0" to "10" span of the Stop Timer Pot is equal to 0 to 10 seconds.
4. For midprocess control or wind up control, the Stop and Stop Timer Pots are always set to "0".
5. When the time on the Stop Timer Pot has elapsed, the Stop Status Lamp will go **"OUT"**, and the Start Status Lamp will come **"ON"**, indicating the Controller is ready to begin the cycle again.

PROBLEMS DURING TEST RUN

Most problems are the result of incorrect installation of the components, or miswiring. Recheck the following points:

1. Is the Tension Sensor correctly sized for both the tension induced load, and the tare weight of the sensing roller and bearings? (See **TENSION SENSOR SPECIFICATIONS**).
2. Are Tension Sensors installed correctly? (Refer to Maintenance Manual L-20127)
3. Is the brake, clutch, or drive being controlled sized correctly? (Refer to Manufacturers Specifications)
4. Are external electrical connections correct? (See **ELECTRICAL CONNECTIONS**).
5. Is the relay contact needed for control of the Automatic Mode wired to the Controller, and correctly timed? (See **ELECTRICAL CONNECTIONS**, Step 6).
6. Is the Power Supply Jumper set to the correct terminals for the AC power being provided? (See **ELECTRICAL CONNECTIONS**).

PROBLEM: Impossible to Achieve Zero Adjustment

1. Is the Tare Weight (The combined weight of the sensing roller and bearings) too great for the Tension Sensor being used? (See **TENSION SENSOR SPECIFICATIONS**).
2. The Tension Sensor will not return to a display of "0" when all force is removed. The Tension Sensor is not mounted to a flat surface, or a side loading force has been applied to the Sensors. Check mounting instructions in Maintenance Manual L-20127 provided with the Sensors)
3. Disconnect the cables from the Tension Sensors, and from Terminals 1 through 8. Check voltage at Terminals 3 and 4, and at Terminals 7 and 8. Correct voltage is approximately 6VDC, fluctuating. If the voltage varies radically, from 6VDC, the Controller is defective.
4. Short across Terminals 1 and 2, and across Terminals 5 and 6. Attempt to achieve Zero Adjustment. If adjustment can be made, the Tension Sensor is defective. If the adjustment cannot be made, or if the Zero Adjustment Pot is near the high or low limit of its range, the Controller is defective.
5. Reconnect cables to the Tension Sensor and to Terminals 1 through 8.

PROBLEM: Impossible to Achieve Span Adjustment

1. If the Tension Indicator varies proportionately to tension changes, but Span Adjustment cannot be made, the Tension Sensor is sized incorrectly, or the wrap angle is too acute. (See **TENSION SENSOR SPECIFICATIONS**).
2. If the Tension Indicator displays the maximum full scale value when a force, less than the maximum, is applied to the sensing roll, and the Span Adjustment Pot for that Sensor is at minimum setting. The Tension Sensor is undersized, or the Sensor is defective.
3. If the Tension Indicator display is less than the applied tension, and the Span Adjustment Pot is set at maximum. The Tension Sensor is oversized, or the Tension Sensor is defective.

PROBLEM: Abnormal Output Signals

1. No output in the Manual Mode, when the Manual Control Pot is rotated from minimum to maximum and back.
 - a. The output wires are misconnected.
 - b. The output fuse is blown (TC 250 does not have an Output Fuse).
 - c. Open circuit in the output connection of TC250.
 - d. Output Switch in "OFF" position.
2. Output becomes maximum or minimum when the web is removed, or when the machine is stopped, and the "Auto" lamp remains lit. Defective relay contacts or timing of the relay connected to Terminals 21 and 25. (See **TEST RUN, Power On; Automatic Mode, Start Status; and Automatic Mode, Automatic Status**).
3. Output varies from maximum to minimum, and Tension Indicator also varies without stabilizing at the Set Point Value. Gain improperly adjusted, or the controlled element (clutch, brake, or drive) is not correctly sized. (See **TEST RUN, Automatic Mode, Automatic Status**, Steps 4 through 10, for proper Gain Adjustment, and Manufacturers Specifications for correct sizing of the controlled element).

NOTE: For further testing of controllers described as "defective" above, refer to **TROUBLE-SHOOTING**.

MAINTENANCE AND TESTING

MAINTENANCE

There is no required maintenance as the Controller has no parts subject to mechanical wear. Proper care must be taken to insure clean air for the EN-40 Electro-Pneumatic convertor, as outlined in Manual L-20097,

provided with the unit. Operating elements, brakes, clutches, motors, etc., must be maintained in accordance with the manufacturer's specifications.

FUSES

Protective fuses are accessible by opening the front panel of the Controller (See Fig. 11). When a fuse blows, turn off power to the Controller, and eliminate the cause of the blown fuse, then replace the fuse.

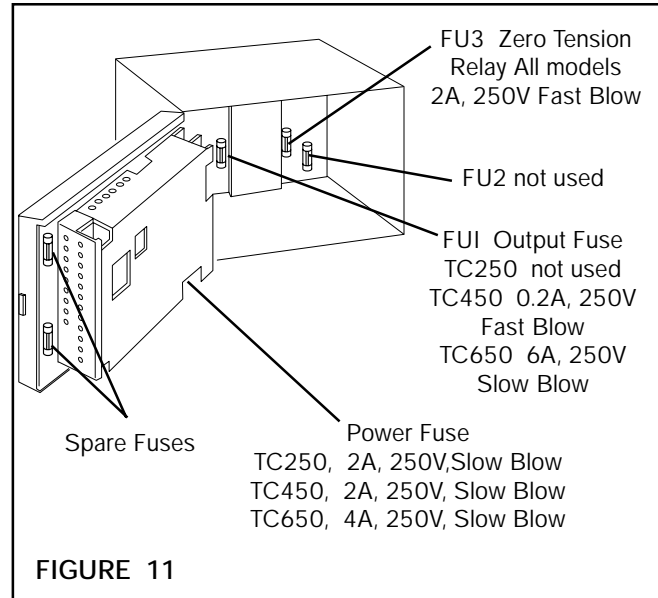

TESTING

1. Remove four Screws which retain the Logic Board Shielding Cover to gain access to the Test Pins used for circuit testing (See Fig. 12).
2. Refer to Figure 13 for placement of Test Pins used for circuit testing.

NOTE: Do not confuse Test Pins CP1 through CP4 on the Display Board, with Test Pins CP1 through CP20 on the Main Logic Board, and Test Pin TP1 on the Main Logic Board.

3. Test Pins CP1 through CP4 on the Display Board are used for calibrating the Analog Diameter, and External Set Point input signals (See **CALIBRATION, Calibration of the Analog Diameter Input, and Calibration of the External Set Point**).
4. Use **TP1** located on the Main Logic Board as **COM** for all tests except Sensor Excitation. For Sensor Excitation, test **CP11** against **CP12**.

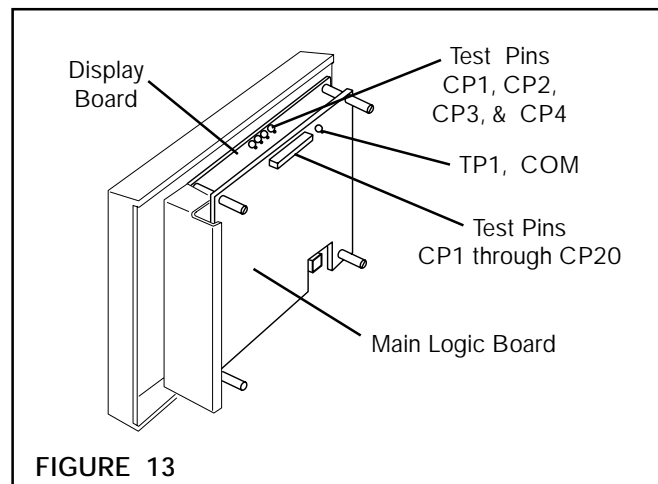
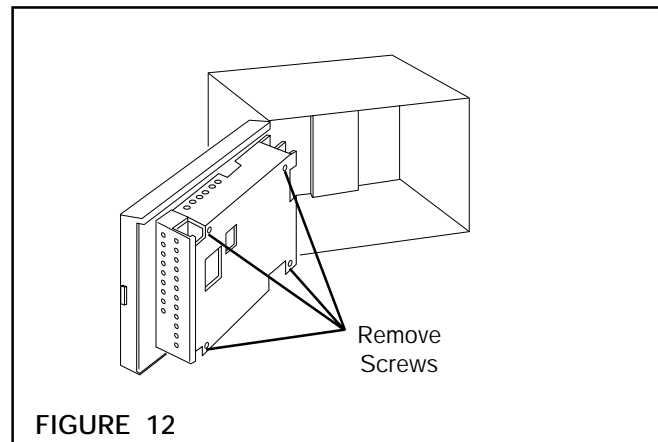
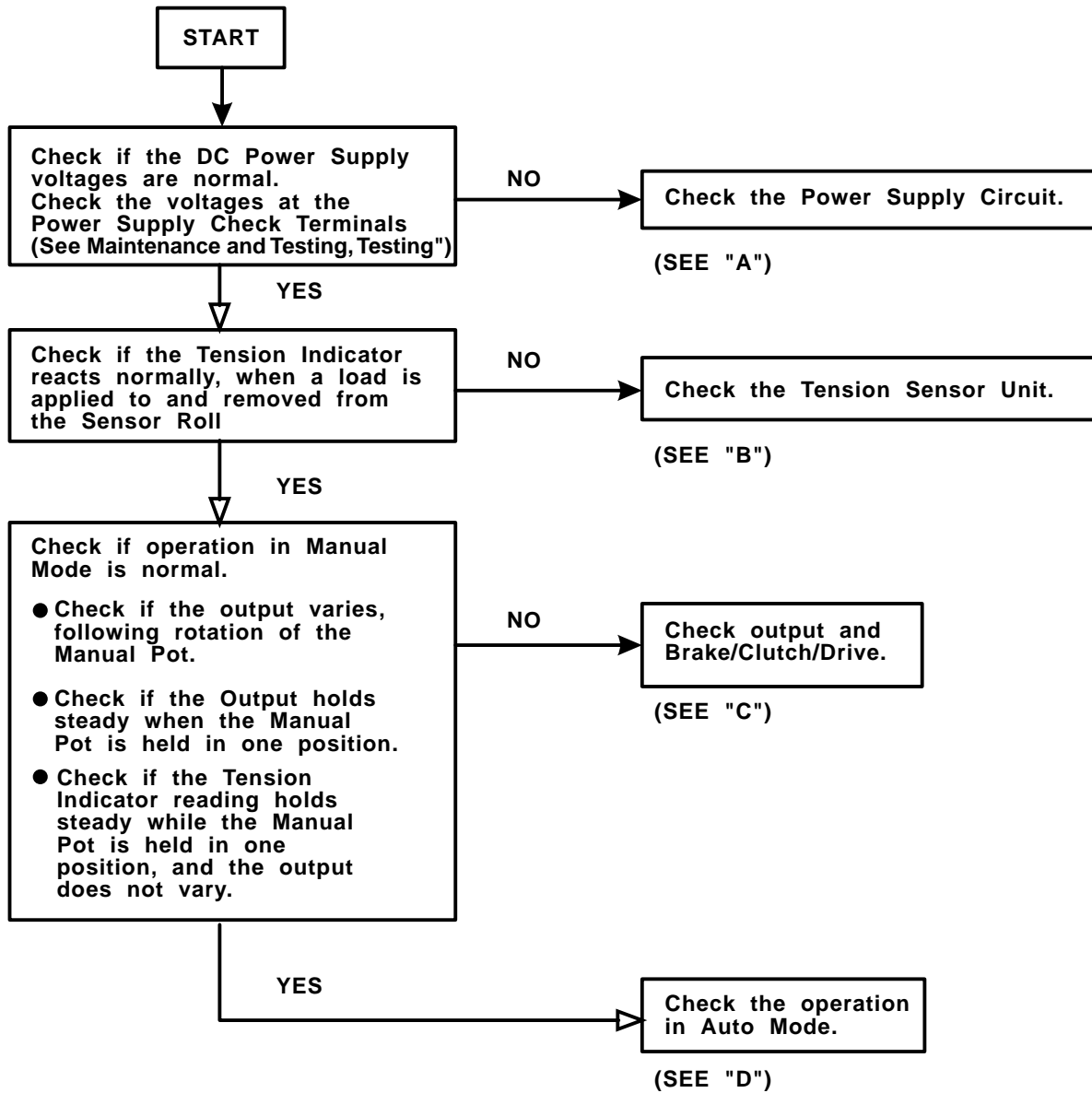

TABLE 4
Test Pin Values, Main Logic Board

	CHECK TERMINALS	CHECK ITEMS	NORMAL CONDITIONS
DC POWER SUPPLY	CP14	Analog Switch Power	Approx. + 8VDC
	CP15	Analog Switch Power	Approx. + 5VDC
	CP16	Operational Amp. Power	Approx. + 15VDC
	CP17	Operational Amp. Power	Approx. -- 15VDC
	CP18	Digital ICs Power	Approx. 5VDC
SIGNAL LINE	CP1	Tension at No. 1 Sensor	CP1 and CP2 should both indicate half of Test Load Value (TLV) ----- Test Load Weight (LB) TLV= _____ x 10VDC ----- Full Scale Reading (LB)
	CP2	Tension at No. 2 Sensor	
	CP3	Analog Diameter	5V with the Max. Dia. Input 0V with the Min. Dia. Input
	CP4	Taper Signal	Varies with Taper Pot setting
	CP5	External Set Point Signal	5V at the full span
	CP6, CP7, & CP8,	Not Used	
	CP9	Total Tension	Total of CP1 and CP2
	CP10	Controller Output	Varies with Model Designation
	CP11 vs CP12	Sensor Excitation	6VDC Fluctuating
	CP13	Not Used	

TROUBLESHOOTING

ISOLATE SECTION WHICH IS CAUSING THE PROBLEM.



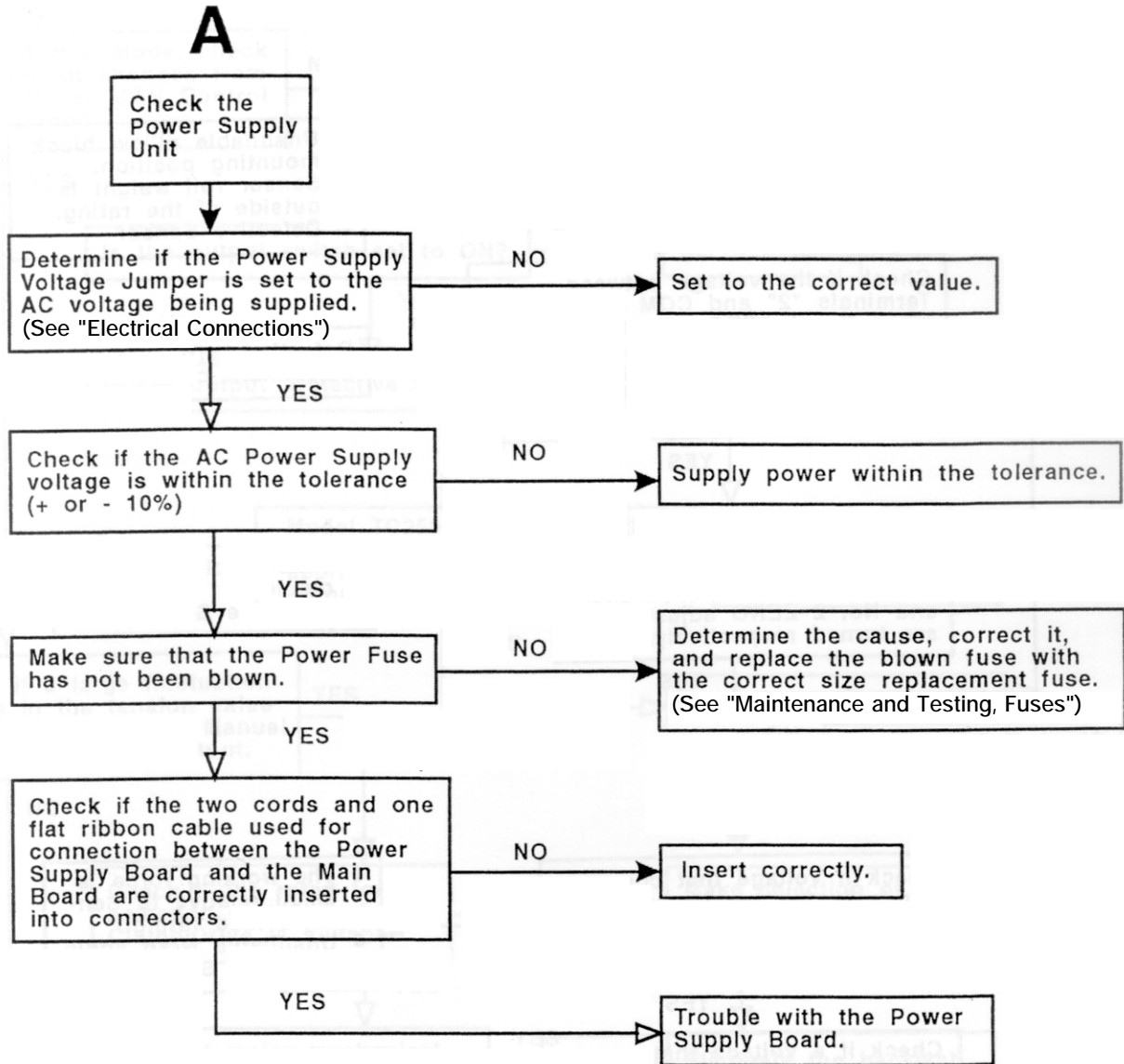

B

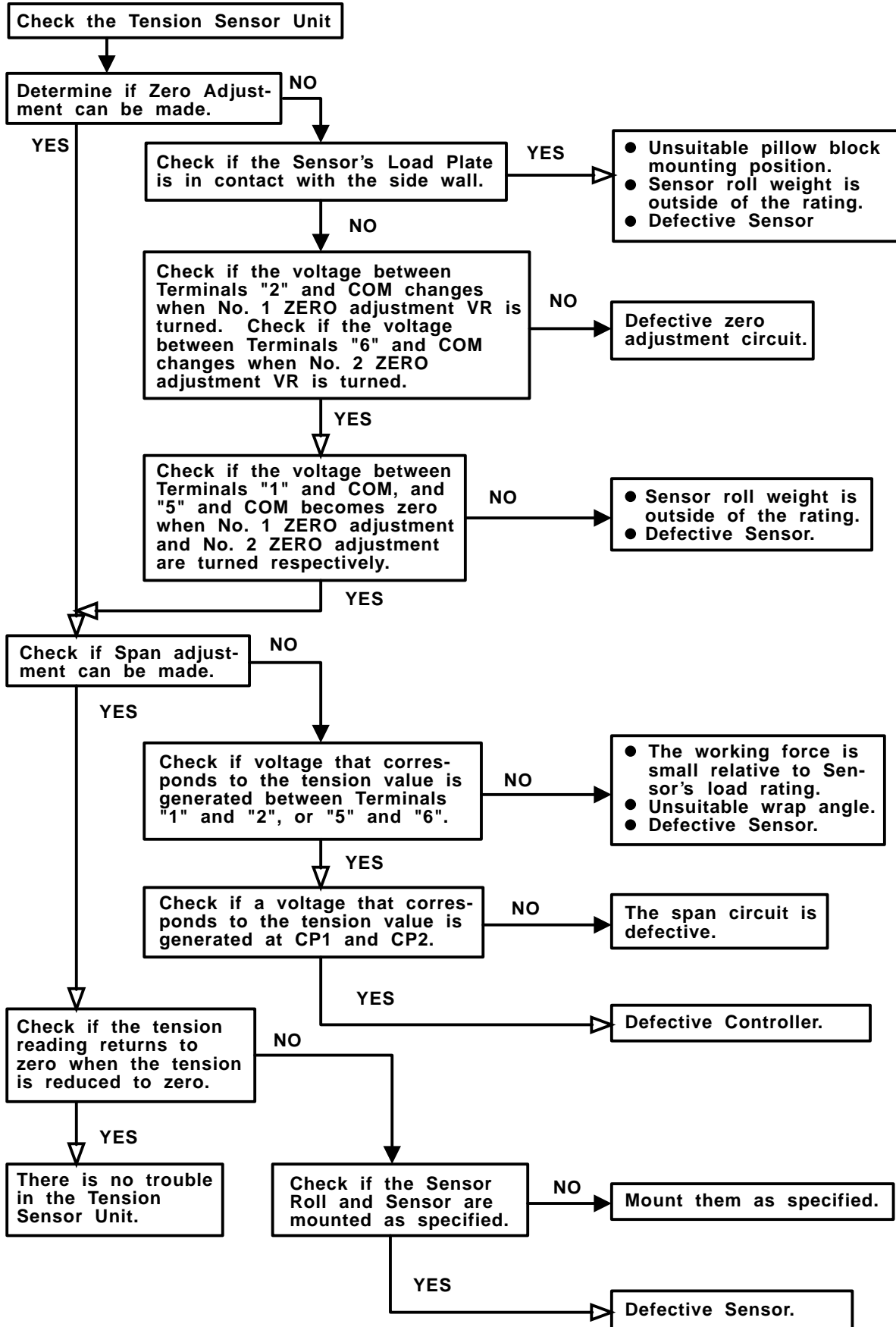

C

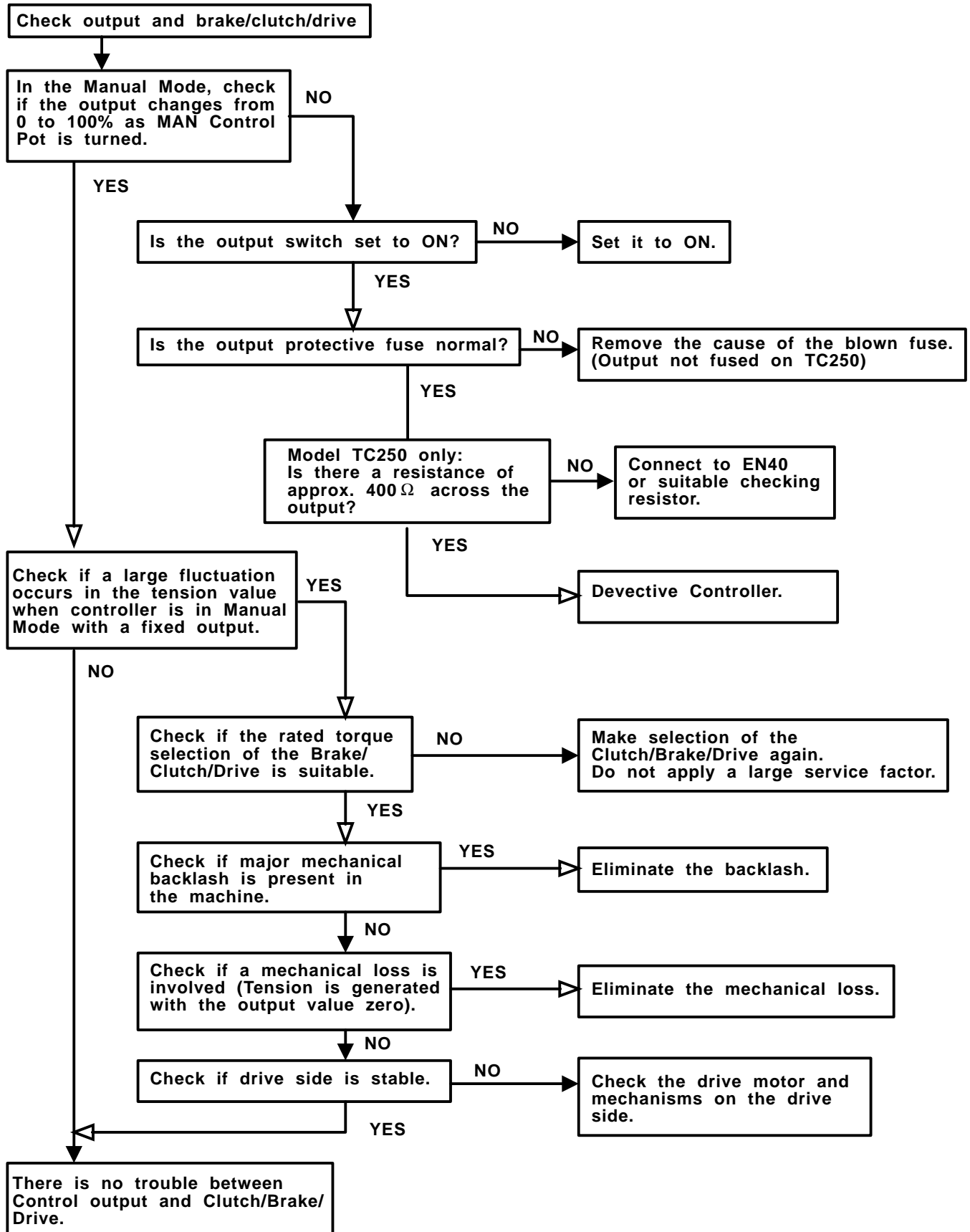



REPLACEMENT PARTS

The item or balloon number for all Nexen products is used for part identification on all product parts lists, product price lists, unit assembly drawings, bills of materials, and instruction manuals.

When ordering replacement parts, specify model designation, item number, part description, and quantity. Purchase replacement parts through your local Nexen Distributor.

ITEM	DESCRIPTION	P/N
1	Power Supply PC Board (TC250)	3365
1	Power Supply PC Board (TC450)	3366
1	Power Supply PC Board (TC650)	3367
2	Main PC Board "A" (All Models)	3368
3	Display Board "B" (All models)	3369
4	Auto Set Point Pot (All Models)	3090
5	Manual Control Pot (All Models)	3090
6	Mode Switch (All Models)	2790
7	Power Switch (All Models)	2791
8	Output Switch (All Models)	2790

TENSION SENSOR SPECIFICATIONS

Product Number	912609	912610	911991	911995	911996	911999	911889	012000	911998
Frame Size	MB05B	MB05A	MB11B	MB11A	MB25B	MB25A	MB33B	MB33A	MB41
Load Range Per Sensor	22lb	44lb	22lb	44lb	110lb	220lb	660lb	1100lb	2200lb
Load Range Per Sensor	10kg	20kg	10kg	20kg	50kg	100kg	300kg	500kg	1000kg
Tare per Sensor	11lb	22lb	11lb	22lb	55lb	110lb	230lb	385lb	770lb
Tare Per Sensor	5kg	10kg	5kg	10kg	25kg	50kg	105kg	175kg	350kg



WARRANTIES

Warranties

Nexen warrants that the Products will be free from any defects in material or workmanship for a period of 12 months from the date of shipment. NEXEN MAKES NO OTHER WARRANTY, EXPRESS OR IMPLIED, AND ALL IMPLIED WARRANTIES, INCLUDING WITHOUT LIMITATION, IMPLIED WARRANTIES OF MERCHANTABILITY AND FITNESS FOR A PARTICULAR PURPOSE ARE HEREBY DISCLAIMED. This warranty applies only if (a) the Product has been installed, used and maintained in accordance with any applicable Nexen installation or maintenance manual for the Product; (b) the alleged defect is not attributable to normal wear and tear; (c) the Product has not been altered, misused or used for purposes other than those for which it was intended; and (d) Buyer has given written notice of the alleged defect to Nexen, and delivered the allegedly defective Product to Nexen, within one year of the date of shipment.

Exclusive Remedy

The exclusive remedy of the Buyer for any breach of the warranties set out above will be, at the sole discretion of Nexen, a repair or replacement with new, serviceably used or reconditioned Product, or issuance of credit in the amount of the purchase price paid to Nexen by the Buyer for the Products.

Limitation of Nexen's Liability

TO THE EXTENT PERMITTED BY LAW NEXEN SHALL HAVE NO LIABILITY TO BUYER OR ANY OTHER PERSON FOR INCIDENTAL DAMAGES, SPECIAL DAMAGES, CONSEQUENTIAL DAMAGES OR OTHER DAMAGES OF ANY KIND OR NATURE WHATSOEVER, WHETHER ARISING OUT OF BREACH OF WARRANTY OR OTHER BREACH OF CONTRACT, NEGLIGENCE OR OTHER TORT, OR OTHERWISE, EVEN IF NEXEN SHALL HAVE BEEN ADVISED OF THE POSSIBILITY OR LIKELIHOOD OF SUCH POTENTIAL LOSS OR DAMAGE. For all of the purposes hereof, the term "consequential damages" shall include lost profits, penalties, delay images, liquidated damages or other damages and liabilities which Buyer shall be obligated to pay or which Buyer may incur based upon, related to or arising out of its contracts with its customers or other third parties. In no event shall Nexen be liable for any amount of damages in excess of amounts paid by Buyer for Products or services as to which a breach of contract has been determined to exist. The parties expressly agree that the price for the Products and the services was determined in consideration of the limitation on damages set forth herein and such limitation has been specifically bargained for and constitutes an agreed allocation of risk which shall survive the determination of any court of competent jurisdiction that any remedy herein fails of its essential purpose.

Limitation of Damages

In no event shall Nexen be liable for any consequential, indirect, incidental, or special damages of any nature whatsoever, including without limitation, lost profits arising from the sale or use of the Products.

Warranty Claim Procedures

To make a claim under this warranty, the claimant must give written notice of the alleged defect to whom the Product was purchased from and deliver the Product to same within one year of the date on which the alleged defect first became apparent.

nexen[®]

Nexen Group, Inc.
560 Oak Grove Parkway
Vadnais Heights, MN 55127

800.843.7445
Fax: 651.286.1099
www.nexengroup.com

ISO 9001 Certified