

AIR CHAMP[®] PRODUCTS

User Manual

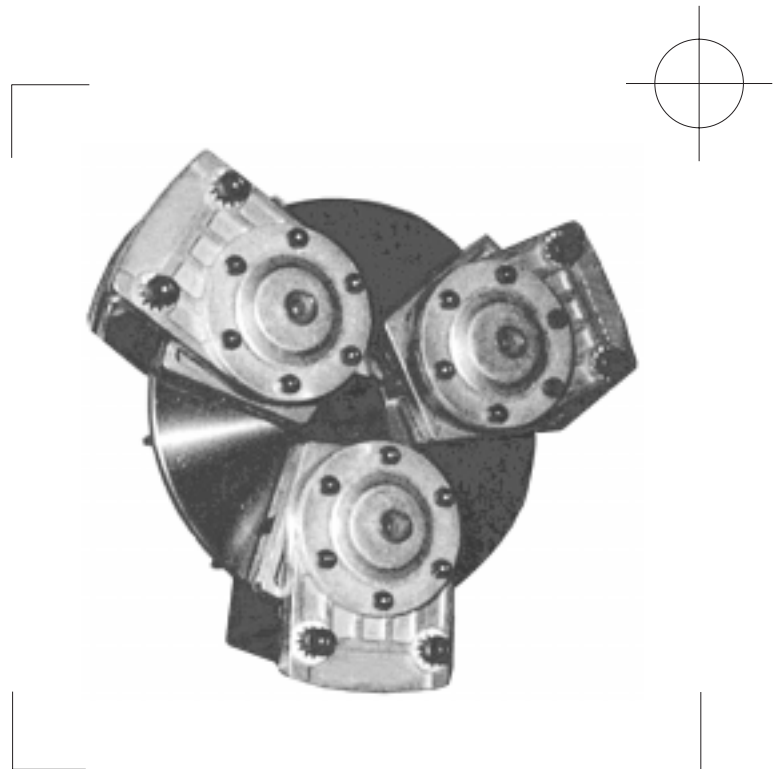

Tension Control Brake Model TCB-7

In accordance with Nexen's established policy of constant product improvement, the specifications contained in this manual are subject to change without notice. Technical data listed in this manual are based on the latest information available at the time of printing and are also subject to change without notice.

Technical Support:
800-843-7445
(651) 484-5900

www.nexengroup.com



WARNING

Read this manual carefully before installation and operation.

Follow Nexen's instructions and integrate this unit into your system with care.

This unit should be installed, operated and maintained by qualified personnel ONLY.

Improper installation can damage your system or cause injury or death.

Comply with all applicable codes.

Nexen Group, Inc.
560 Oak Grove Parkway
Vadnais Heights, Minnesota 55127



TABLE OF CONTENTS

Introduction ----- 1

Installation ----- 2

Air Connections ----- 3

Operation ----- 3

Maintenance ----- 3

Troubleshooting ----- 4

Parts Replacement ----- 4

Replacement Parts ----- 6

Parts List ----- 7

Accessories ----- 7

Warranties ----- 8



INTRODUCTION

Read this manual carefully, making full use of its explanations and instructions. The “Know How” of safe, continuous, trouble-free operation depends on the degree of your understanding of the system and your willingness to keep all components in proper operating condition. Pay particular attention to all NOTES, CAUTIONS, and WARNINGS to avoid the risk of personal injury or property damage. It is important to understand that these NOTES, CAUTIONS, and WARNINGS are not exhaustive. Nexen cannot possibly know or evaluate all conceivable methods in which service may be performed, or the possible hazardous consequences of each method. Accordingly, anyone who uses a procedure that is not recommended by Nexen must first satisfy themselves that neither their safety or the safety of the product will be jeopardized by the service method selected.



WARNING

Per OSHA regulations, Nexen recommends using a guard that will not restrict the flow of cooling air around the unit if the unit has rotating parts. Contact your local Nexen Distributor for information about guards designed for the Nexen TCB-7.

INSTALLATION



WARNING

Do not flange mount the TCB-7. Flange mounting will result in damage to the TCB-7 Housing.

1. Insert the Nexen supplied Key (Item 6) into the machine shaft (See Figure 1).
2. Slide the TCB-7 onto the machine shaft (See Figure 1).
3. Tighten Set Screws (Item 3) to 7 Ft. Lbs. [9.5 N•m] torque (See Figure 1).

NOTE: Runout of the Friction Disc Hub (Item 2) must be less than 0.015" [0.381 mm] TIR. Runout is minimized if a dial indicator is used as Set Screws (Item 3) are tightened. Place contact tip of dial indicator on machined surface of Friction Disc Hub to measure runout.

4. Using the Flat Head Screw (Item 10) provided with the Friction Facing (Item 9), secure a Friction Facing to each Caliper Assembly.
5. Using the Spacers (Item 5), Lock Washers (Item 18), and Socket Head Cap Screws (Item 19), secure Caliper Assemblies to Housing (Item 1) (See Figure 2).
6. Tighten Socket Head Cap Screws (Item 19) to 27 Ft. Lbs. [36.4 N•m] torque.

NOTE: The TCB-7 is designed to be held from rotation by an arm or a linkage sufficient to prevent rotation, but loose enough to avoid thrust loads on the bearing or brake housing.

7. Using a customer supplied 5/16 UNC Cap Screw, secure a Torque Arm to the TCB-7 to prevent rotation of the TCB-7 (See Figure 3).

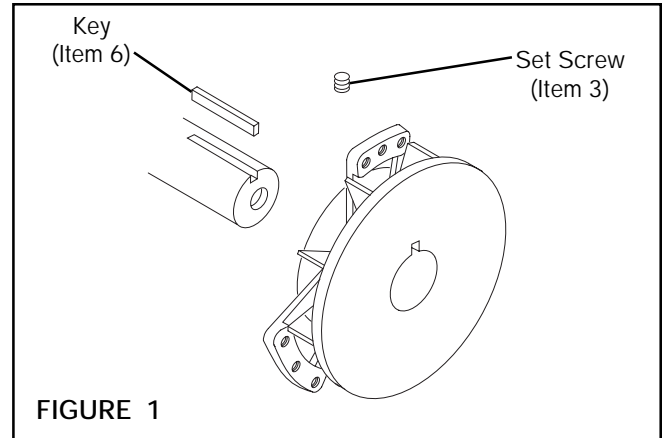

FIGURE 1

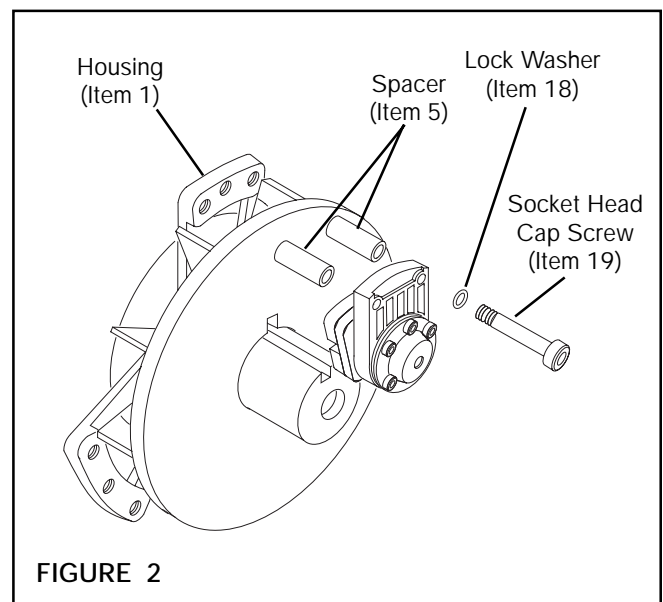

FIGURE 2

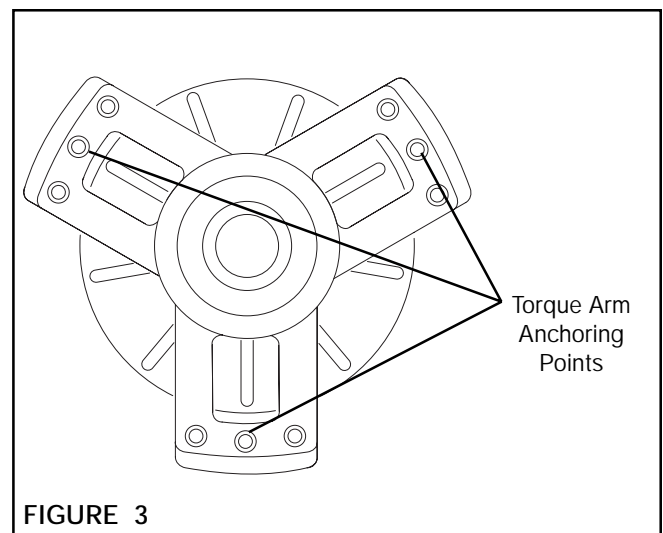
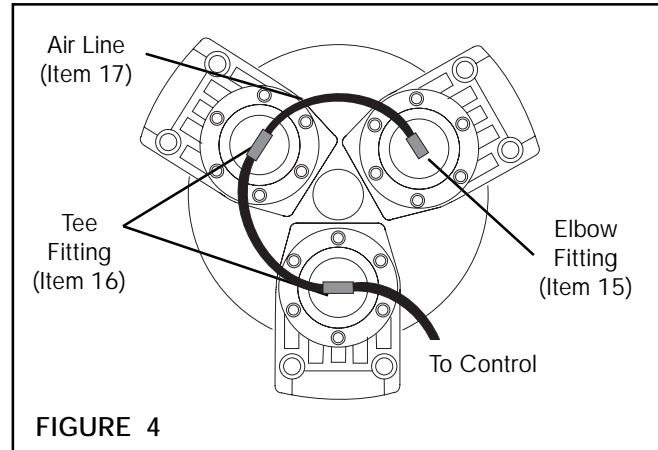

FIGURE 3



AIR CONNECTIONS

1. Install a Elbow Fitting (Item 15) into one Caliper Assembly (See Figure 4).
2. Install the Tee Fittings (Item 16) into the remaining Caliper Assemblies (See Figure 4).
3. Cut the Air Line (Item 17) to length and push it into the Elbow and Tee Fittings (Items 15 and 16) (See Figure 4).
4. Connect the remaining length of Air Line to the control output port or connection (See Figure 4).
5. Connect the air supply to the control input port or connection (See Figure 4).



OPERATION

For optimum brake operation, connect the controls as close to the TCB-7 as possible. Nexen Manufacturing recommends the installation of a filter in the Air Line ahead of the control.

For automatic tension control, use Nexen's Electronic Tension Control System. Contact your local Horton Web Handling distributor or representative for information concerning this product.



WARNING

Never exceed the maximum operating speed of 4000 RPM. Before placing TCB-7 into service, check that the Socket Head Cap Screws (Item 19) are tightened to 27 Ft. Lbs. [36.4 N·m] torque (See Table 1).

MAINTENANCE

Inspect all cap screws and set screws on a routine basis to make sure they are tightened to the recommended torque.

Inspect Friction Facings and replace them when worn to approximately 5/32" [4 mm] thick.

TROUBLESHOOTING

SYMPTOM	PROBABLE CAUSE	SOLUTION
Failure to engage	Air not getting to the TCB-7.	Check for control valve malfunction or low air pressure.
Failure to disengage	Unexhausted air.	Check for control valve malfunction.
Friction Facing squeal or chatter	Air pressure too high.	Reduce air pressure.
	Wrong Friction Facing for the application.	Check the Friction Facing.
	Runout of the Friction Disc Hub is too great.	Runout of the Friction Disc Hub must be less than 0.015" [0.381 mm] TIR. If the Friction Disc Hub runout is greater than 0.015" [0.381 mm] the disc must be reinstalled.
Wobble or vibration	Improper TCB-7 mounting.	Check mounting and reinstall the TCB-7 if necessary.
	Faulty shaft.	Inspect the shaft and replace it if necessary.

PARTS REPLACEMENT

FRICTION FACINGS

1. Stop the machine and shut off the air supply to the TCB-7.
2. Disconnect the Air Lines.
 - a. To disconnect the Air Line, push in on the collar of the fitting and pull the Air Line out (See Figure 5).
 - b. To reconnect the Air Line, push it into the fitting until it stops.
3. Remove the Socket Head Cap Screws (Item 19) and Lock Washers (Item 18) (See Figure 6).
4. Remove the Caliper Assembly from the Housing.
5. Remove the Flat Head Screw (Item 10) from the back of the Caliper Assembly and remove the old Friction Facing (Item 9) (See Figure 7).
6. Install a new Friction Facing (Item 9) and secure it to the Caliper Assembly with a new Flat Head Screw (Item 10). Tighten the Flat Head Screw to 18-19 In. Lbs. [2.0-2.1 N•m].
7. Place the Caliper Assembly in position and secure it to the Housing with the Socket Head Cap Screws (Item 19) and Lock Washers (Item 18) (See Figure 6).
8. Tighten the Socket Head Cap Screws (Item 19) to 27 Ft. Lbs. [36.4 N•m] torque.
9. Reconnect the Air Lines.

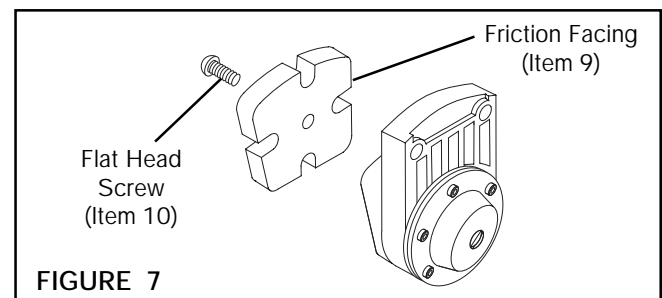
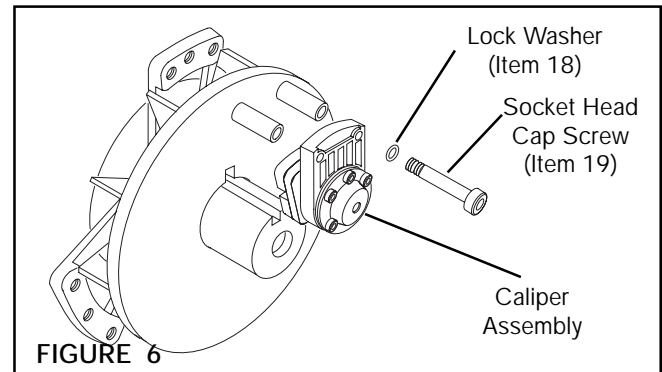
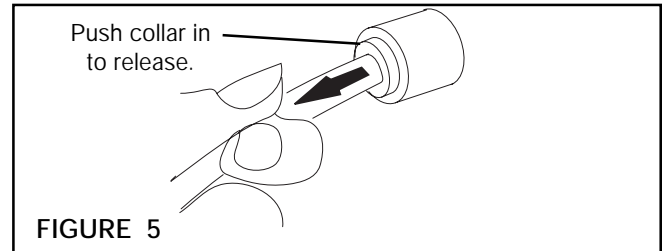

DIAPHRAGM

1. Proceed with Steps 1 - 4 of **PARTS REPLACEMENT—FRICTION FACINGS**.
2. Remove the six Socket Head Cap Screws (Item 20) and Cover (Item 13) from the Cylinder (Item 11) (See Figure 8).
3. Remove Diaphragm (Item 14) (See Figure 8).

NOTE: Internal Compression Springs (Item 41) may also be removed at this time. These springs are optional; the low air pressure setting is more sensitive without the springs (See Figure 8).

4. Install a new Diaphragm with the rubber (not fabric) on the air side and reassemble the Caliper Assembly.
5. Tighten the Socket Head Cap Screws (Item 20) to 5.5 Ft. Lbs. [7.45 N•m] torque (See Figure 8).
6. Proceed with Steps 7 - 9 of **PARTS REPLACEMENT—FRICTION FACINGS**.

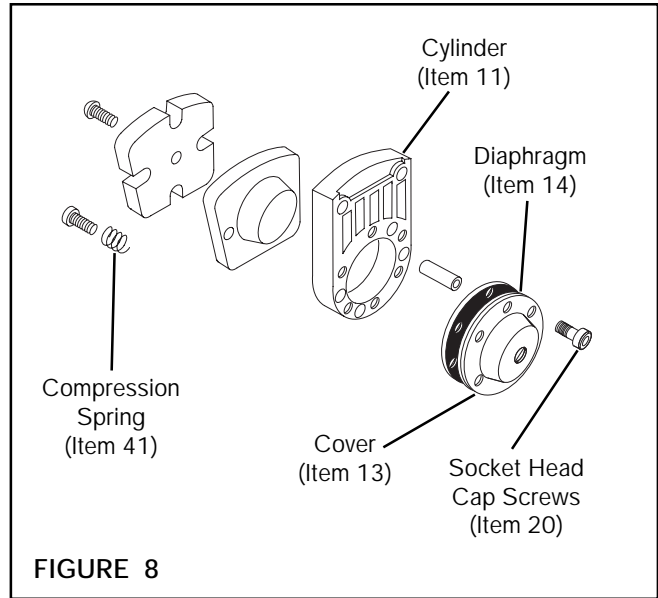

BEARING REPLACEMENT

1. Proceed with Steps 1 - 4 of **PARTS REPLACEMENT—FRICTION FACINGS**.
2. Loosen Set Screws (Item 3) and remove TCB-7 Housing and Rotor from machine shaft (See **INSTALLATION**).

 **WARNING**

Special attention should be exercised when working with retaining rings. Always wear safety goggles when working with spring or tension loaded fasteners or devices.

3. Remove Retaining Ring (Item 7) (See Figure 9).
4. Fully supporting Housing (Item 1), press the Friction Disc Hub (Item 2) out of the Bearing (Item 4) and Housing (Item 1) (See Figure 9).
5. Remove the Retaining Ring (Item 8) (See Figure 9).

6. Fully supporting Housing (Item 1), press the old Bearing (Item 4) out of the Housing (Item 1) (See Figure 9).
7. Clean the bearing bore of the Housing with safety solvent making sure all Loctite® residue is removed.
8. Apply an adequate amount of Loctite® 680 to evenly coat the outer race of the new Bearing (Item 4); then, align the new Bearing with the bore of Housing and press the new Bearing into place.
9. Install Retaining Ring (Item 8) (See Figure 9).
10. Slide Friction Disc Hub (Item 2) into Bearing (Item 4) and Housing (Item 1) (See Figure 9).
11. Install Retaining Ring (Item 7) (See Figure 9).
12. Proceed with Steps 7 - 9 of **PARTS REPLACEMENT—FRICTION FACINGS**.
13. Install TCB-7 (See **INSTALLATION**).

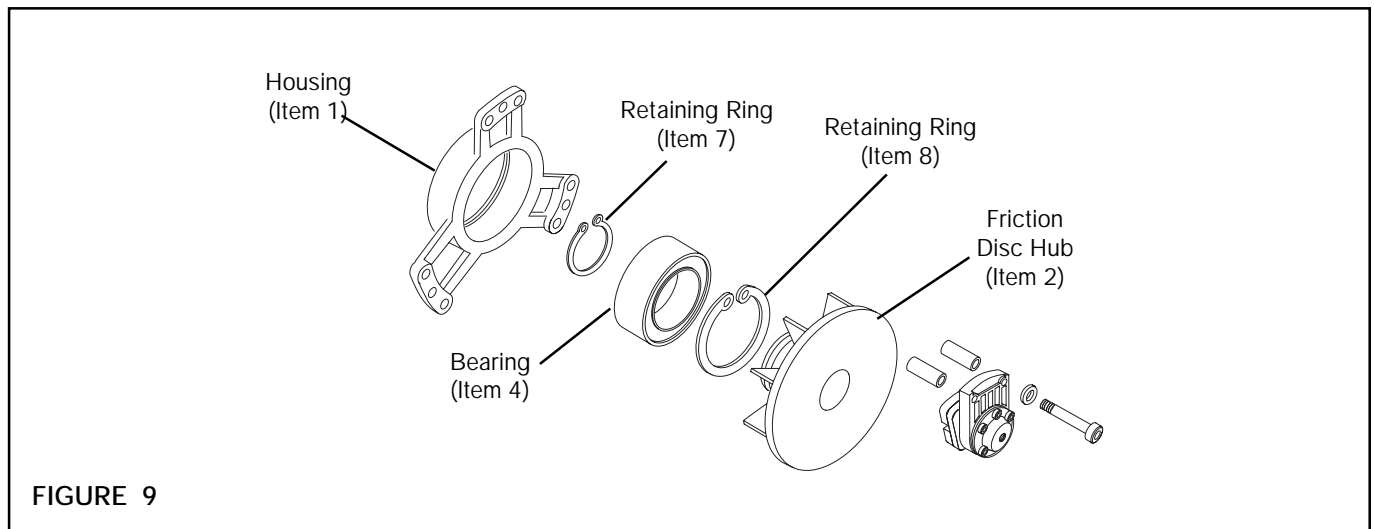

REPLACEMENT PARTS

The item or balloon number for all Nexen products is used for part identification on all product parts lists, product price lists, unit assembly drawings, bills of materials, and instruction manuals.

When ordering replacement parts, specify model designation, item number, part description, and quantity. Purchase replacement parts through your local Nexen Distributor.

PARTS LIST

ITEM	DESCRIPTION	QTY
1	Housing	1
2	Friction Disc Hub	1
3	Set Screw (Not Shown)	3
4	Bearing	1
5	Spacer	2
6	Key (Not Shown)	1
7	Retaining Ring (Ext.)	1
8	Retaining Ring (Int.)	1
9	Friction Facing	3
10	Flat Head Screw	3
11	Cylinder	1 ¹
12	Piston	1 ¹
13	Cover	1 ¹
14	Diaphragm	1 ¹
15	Elbow Fitting (Not Shown)	1
16	Tee Fitting (Not Shown)	1
17	Air Line (Not Shown)	--
18	Lock Washer (Ext. Tooth)	6
19	Socket Head Cap Screw	6
20	Socket Head Cap Screw	6
21	Spring Pin	2 ¹
40	Socket Head Cap Screw	2 ¹
41	Compression Spring	2 ¹

¹ Quantity shown is for one (1) Caliper Assembly only.

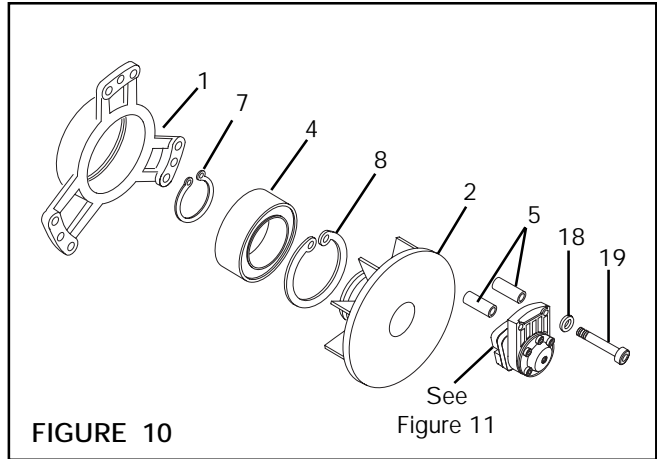
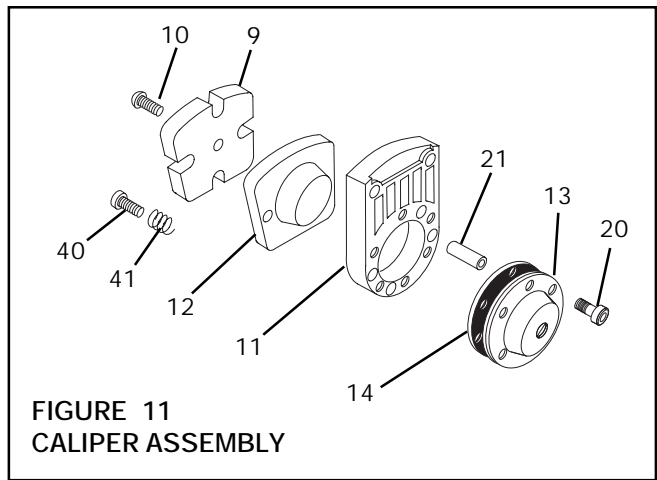

FIGURE 10

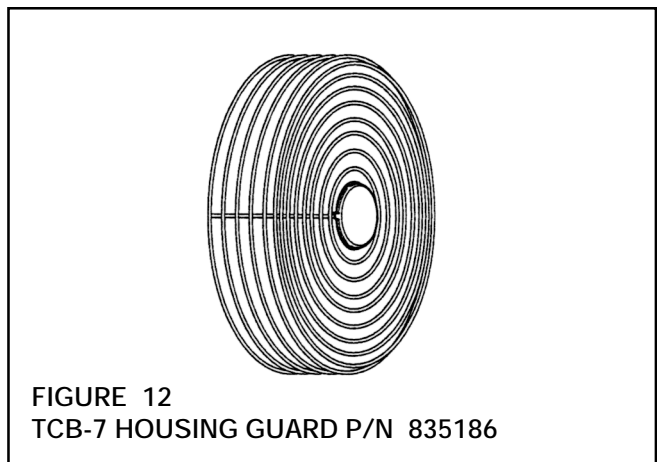

**FIGURE 11
CALIPER ASSEMBLY**

ACCESSORIES

WARNING

Per OSHA regulations, Nexen recommends using a guard that will not restrict the flow of cooling air around the unit if the unit has rotating parts. Contact your local Nexen Distributor for information about guards designed for the Nexen TCB-7.



**FIGURE 12
TCB-7 HOUSING GUARD P/N 835186**



WARRANTIES

Warranties

Nexen warrants that the Products will be free from any defects in material or workmanship for a period of 12 months from the date of shipment. NEXEN MAKES NO OTHER WARRANTY, EXPRESS OR IMPLIED, AND ALL IMPLIED WARRANTIES, INCLUDING WITHOUT LIMITATION, IMPLIED WARRANTIES OF MERCHANTABILITY AND FITNESS FOR A PARTICULAR PURPOSE ARE HEREBY DISCLAIMED. This warranty applies only if (a) the Product has been installed, used and maintained in accordance with any applicable Nexen installation or maintenance manual for the Product; (b) the alleged defect is not attributable to normal wear and tear; (c) the Product has not been altered, misused or used for purposes other than those for which it was intended; and (d) Buyer has given written notice of the alleged defect to Nexen, and delivered the allegedly defective Product to Nexen, within one year of the date of shipment.

Exclusive Remedy

The exclusive remedy of the Buyer for any breach of the warranties set out above will be, at the sole discretion of Nexen, a repair or replacement with new, serviceably used or reconditioned Product, or issuance of credit in the amount of the purchase price paid to Nexen by the Buyer for the Products.

Limitation of Nexen's Liability

TO THE EXTENT PERMITTED BY LAW NEXEN SHALL HAVE NO LIABILITY TO BUYER OR ANY OTHER PERSON FOR INCIDENTAL DAMAGES, SPECIAL DAMAGES, CONSEQUENTIAL DAMAGES OR OTHER DAMAGES OF ANY KIND OR NATURE WHATSOEVER, WHETHER ARISING OUT OF BREACH OF WARRANTY OR OTHER BREACH OF CONTRACT, NEGLIGENCE OR OTHER TORT, OR OTHERWISE, EVEN IF NEXEN SHALL HAVE BEEN ADVISED OF THE POSSIBILITY OR LIKELIHOOD OF SUCH POTENTIAL LOSS OR DAMAGE. For all of the purposes hereof, the term "consequential damages" shall include lost profits, penalties, delay images, liquidated damages or other damages and liabilities which Buyer shall be obligated to pay or which Buyer may incur based upon, related to or arising out of its contracts with its customers or other third parties. In no event shall Nexen be liable for any amount of damages in excess of amounts paid by Buyer for Products or services as to which a breach of contract has been determined to exist. The parties expressly agree that the price for the Products and the services was determined in consideration of the limitation on damages set forth herein and such limitation has been specifically bargained for and constitutes an agreed allocation of risk which shall survive the determination of any court of competent jurisdiction that any remedy herein fails of its essential purpose.

Limitation of Damages

In no event shall Nexen be liable for any consequential, indirect, incidental, or special damages of any nature whatsoever, including without limitation, lost profits arising from the sale or use of the Products.

Warranty Claim Procedures

To make a claim under this warranty, the claimant must give written notice of the alleged defect to whom the Product was purchased from and deliver the Product to same within one year of the date on which the alleged defect first became apparent.

nexen[®]

Nexen Group, Inc.
560 Oak Grove Parkway
Vadnais Heights, MN 55127

800.843.7445
Fax: 651.286.1099
www.nexengroup.com

ISO 9001 Certified