

AIR CHAMP® PRODUCTS

User Manual

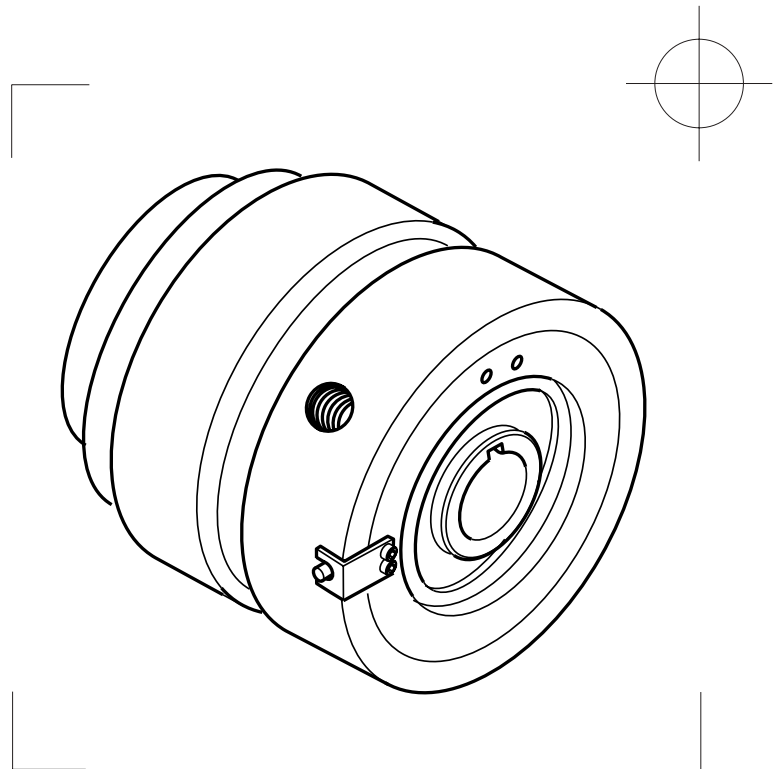

Single-Position Detent Clutch DC Series

In accordance with Nexen's established policy of constant product improvement, the specifications contained in this manual are subject to change without notice. Technical data listed in this manual are based on the latest information available at the time of printing and are also subject to change without notice.

Technical Support:
800-843-7445
(651) 484-5900

www.nexengroup.com



WARNING

Read this manual carefully before installation and operation.

Follow Nexen's instructions and integrate this unit into your system with care.

This unit should be installed, operated and maintained by qualified personnel ONLY.

Improper installation can damage your system or cause injury or death.

Comply with all applicable codes.

Nexen Group, Inc.
560 Oak Grove Parkway
Vadnais Heights, Minnesota 55127

TABLE OF CONTENTS

Introduction ----- 1

Hub Preparation ----- 2

Installation ----- 3

Air Connections ----- 4

Lubrication ----- 4

Operation ----- 5

Parts Replacement ----- 6

Replacement Parts ----- 9

Repair Kits ----- 9

Parts List ----- 10

Warranties ----- 11

INTRODUCTION

Read this manual carefully, making full use of its explanations and instructions. The “Know How” of safe, continuous, trouble-free operation depends on the degree of your understanding of the system and your willingness to keep all components in proper operating condition. Pay particular attention to all NOTES, CAUTIONS, and WARNINGS to avoid the risk of personal injury or property damage. It is important to understand that these NOTES, CAUTIONS, and WARNINGS are not exhaustive. Nexen cannot possibly know or evaluate all conceivable methods in which service may be performed, or the possible hazardous consequences of each method. Accordingly, anyone who uses a procedure that is not recommended by Nexen must first satisfy themselves that neither their safety or the safety of the product will be jeopardized by the service method selected.

Nexen’s Single Position DC Series Clutches provide exact timing between two shafts or gears. The Single Position DC is designed to engage at the same position for perfect registration every time.

All DC Series Clutches operate on static air pressure, requiring only minimal amounts of air per engagement. Because Nexen’s DC Series Clutches operate on static air pressure, torque output can be changed by simply changing the air pressure setting.

HUB PREPARATION

NOTE: This Section pertains only to DC Series Clutches that are finished bored by the customer. If your DC Series Clutch has been finished bored at the factory, proceed to **INSTALLATION**.

After the Hub has been finished bored, drill and tap Hub for set screws. Set screw locations are over keyway and at 90o off keyway. Models DC10 and DC15 require two set screws located on the Drive Flange of the Hub. Models DC20 and higher require two set screws located on both ends of the Hub (Refer to Table 1 for Set Screws and Tap sizes).

TABLE 1

MODEL	U.S.	METRIC	QTY.
DC10	10-24	M5-0.8	2
DC15	10-24	M5-0.8	2
DC20	1/4-20	M6-1.0	4
DC30	5/16-24	M6-1.0	4
DC40	3/8-24	M10-1.5	4
DC50	3/8-24	M10-1.5	4
DC60	1/2-13	M12-1.75	4
DC70	1/2-13	M12-1.75	4
DC80	1/2-13	M12-1.75	4

DC SERIES CLUTCH ASSEMBLY

1. Fully supporting Bearings (Item 21), press Finished Bored Hub (Item 7) into place (See Fig. Fig. 1)
2. Install Retaining Ring (Item 6) onto Drive Flange end of DC Series Clutch. (See Fig. 1).
3. Lubricate Drive Flange Assembly (See Table 2) for recommended lubricants). Spread lubricant (approx. 1/4" [6.4 mm] thick by 1/4" [6.4 mm] wide) evenly over Drive Flange Balls, Ball Track, and Drive Ring Detents.

TABLE 2

RECOMMENDED LUBRICANTS
Chevron SRI Amoco Rykon Premium Grease #2 Exxon Unirex #2 Shell Dolium Grease #2 Texaco Premium #2

NOTE: On DC80, spread lubricant approx. 3/8" [9.2 mm] thick by 3/8" [9.2 mm] wide over Drive Flange Balls, Ball Track, and Drive Ring Detents.

CAUTION

Do not over lubricate Drive Flange Assembly. Over lubricating creates a hydraulic effect within the DC Series Clutch which will adversely affect the breakaway torque.

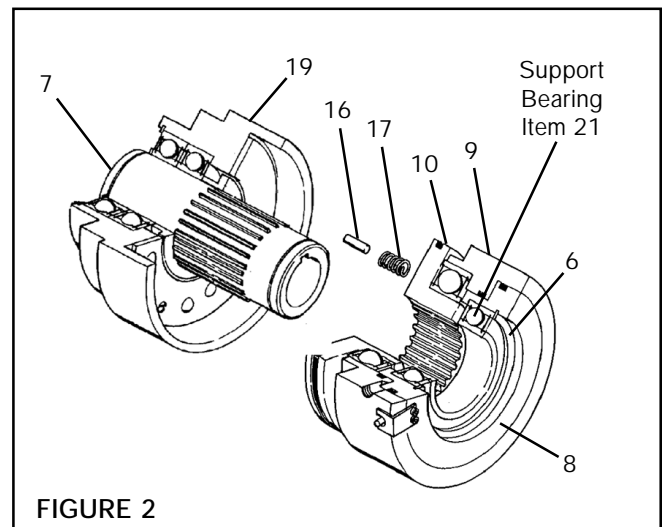
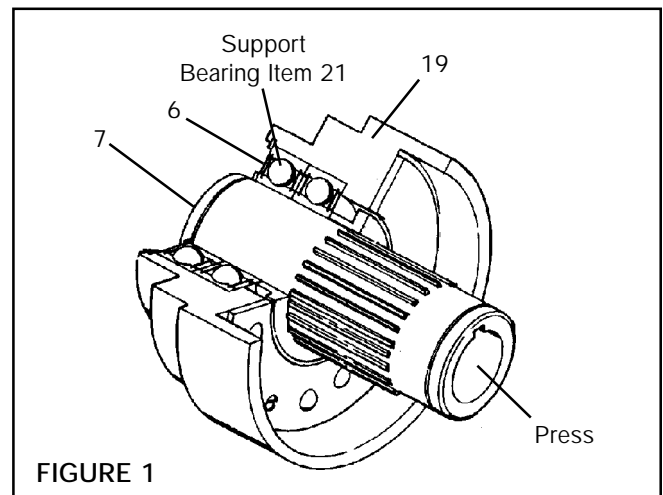

4. Install Springs (Item 21), and Spring Stiffener Pin (Item 16) into respective holes in Ring Drive (Item 10) (See Fig. 2).

NOTE: When reassembling DC Series Clutch halves, align Hub keyway with Detents as shown (See Fig. 3).

5. Fully supporting Bearing (Item 21), press Cylinder/Piston Assembly (Items 8 & 9) onto Hub (Item 7) (See Fig. 2).
6. Install Retaining Ring (Item 6) on Cylinder/Piston end of DC Series Clutch (See Fig. 2).

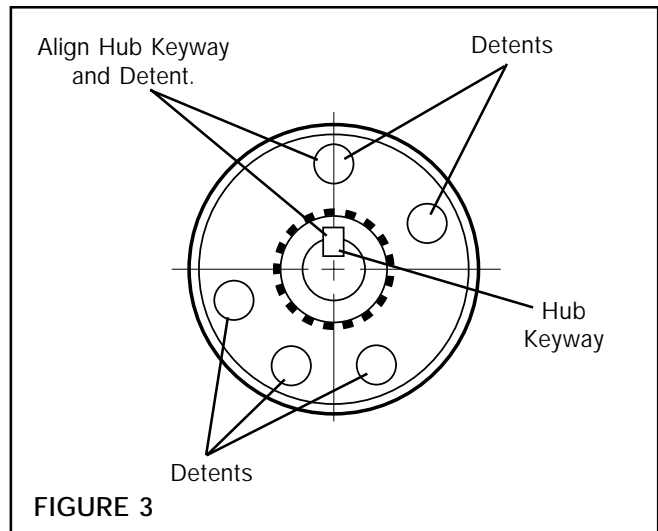

INSTALLATION

1. Using customer supplied cap screws, fasten sheave or sprocket to DC Series Clutch (See Fig. 4).
2. Insert customer supplied key into shaft keyway (See Fig. 4).
3. Align keyway of DC Series Clutch with shaft and key, then slide DC Series Clutch onto shaft (See Fig. 4).
4. Tighten Set Screws to recommended torque (See Table 3).

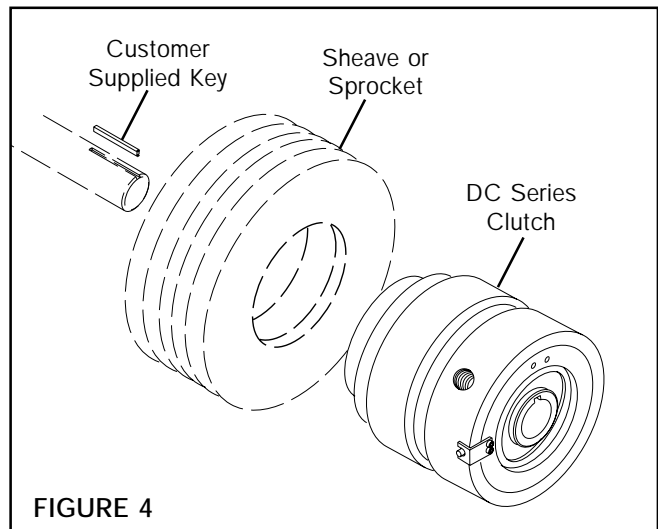

TABLE 3

SET SCREW TORQUE SPECIFICATIONS	
DC-10	5 ft. lbs. [73 N/m]
DC-15	5 ft. lbs. [73 N/m]
DC-20	7 ft. lbs. [102 N/m]
DC-30	14 ft. lbs. [204 N/m]
DC-40	24 ft. lbs. [350 N/m]
DC-50	24 ft. lbs. [350 N/m]
DC-60	51 ft. lbs. [744 N/m]
DC-70	51 ft. lbs. [744 N/m]
DC-80	51 ft. lbs. [744 N/m]

AIR CONNECTIONS

All Nexen pneumatically actuated devices require clean, lubricated air for maximum performance and long life. Your Nexen Distributor carries filters, regulators, and lubricators specifically designed to operate with Nexen products.

CAUTION
 Do not use rigid pipe or tubing when making air line connections. Torque on the air line, caused by bearing drag may be relieved by resting the air line on a support parallel to the DC Series Clutch centerline.

For fast response, a short air line and quick exhaust valve is recommended between the control valve and DC Series Clutch.

Align DC Series Clutch air inlet to the six o'clock down position to allow condensation in the air chamber to drain out of the exhaust port.

LUBRICATION

Nexen's DC Series Clutch bearings are shielded and prefabricated and require no further lubrication.

The Drive Flange Assembly has been prefabricated, and does not require additional lubrication at start up. The amount of lubrication is sufficient to maintain the proper coefficient of friction at the balls and detents.

The Drive Flange Assembly must be disassembled if relubrication becomes necessary (See **PARTS REPLACEMENT**). Spread recommended lubricant (approx. 1/4" [6.4 mm] thick by 1/4" [6.4 mm] wide) evenly over Drive Flange Balls, Ball Track, and Drive Ring Detents (See Table 4 for recommended lubricants).

NOTE: On DC-80, spread lubricant approx. 3/8" [9.2 mm] thick by 3/8" [9.2 mm] wide over Drive Flange Balls, Ball Track, and Drive Ring Detents.

TABLE 4

RECOMMENDED LUBRICANTS
Chevron SRI Amoco Rykon Premium Grease #2 Exxon Unirex #2 Shell Dollium Grease #2 Texaco Premium #2

CAUTION
 Do not over lubricate Drive Flange Assembly. Over lubricating creates a hydraulic effect within the DC Series Clutch which will adversely affect the breakaway torque.

OPERATION

Nexen's DC Series Clutches Ball and Detent design resets in the same position when the DC Series Clutch is engaged, and delivers the same torque in either direction of rotation.

NOTE: Machine must come to a complete stop before DC Series Clutch can be re-engaged.

WARNING

Never exceed maximum operating speeds listed in Table 5.

TABLE 5

MAXIMUM OPERATING SPEEDS			
Model	Disengaged	Engaged	Torque Up To
DC-10	2000 R.P.M.	3000 R.P.M.	1.4 ft. lbs. [20 N/m]
DC-15	2000 R.P.M.	3000 R.P.M.	3 ft. lbs. [45 N/m]
DC-20	1800 R.P.M.	2000 R.P.M.	6.9 ft. lbs. [100 N/m]
DC-30	1650 R.P.M.	2000 R.P.M.	17.8 ft. lbs. [260 N/m]
DC-40	1350 R.P.M.	1500 R.P.M.	34 ft. lbs. [500 N/m]
DC-50	1200 R.P.M.	1500 R.P.M.	51.4 ft. lbs. [750 N/m]
DC-60	1050 R.P.M.	1300 R.P.M.	89 ft. lbs. [1300 N/m]
DC-70	950 R.P.M.	1300 R.P.M.	123 ft. lbs. [1800 N/m]
DC-80	850 R.P.M.	1300 R.P.M.	231 ft. lbs. [3375 N/m]

WARNING

Do not operate DC Series Clutch in disengaged mode for extended periods of time.

PARTS REPLACEMENT

DC SERIES CLUTCH REMOVAL & DISASSEMBLY

1. Shut off machine and air supply.
2. Remove DC Series Clutch from machine.

CAUTION

Correct alignment of internal components of the DC Series Clutch is critical for proper operation. Before disassembling the DC Series Clutch, mark Hub, Cylinder, and Drive Flange with chalk alignment marks to insure correct alignment of internal components when reassembling DC Series Clutch.

3. Remove Retaining Ring (Item 6) from Hub (Item 7) on Piston (Item 8) end of DC Series Clutch (See Fig. 5).



WARNING

Special attention should be exercised when working with retaining rings. Always wear safety goggles when working with spring or tension loaded fasteners or devices.

5. Supporting Cylinder (Item 9), press Hub (Item 7) and Drive Flange (Item 19) end of Torque DC Series Clutch clear of cylinder end of DC Series Clutch (See Figs. 5 & 6).

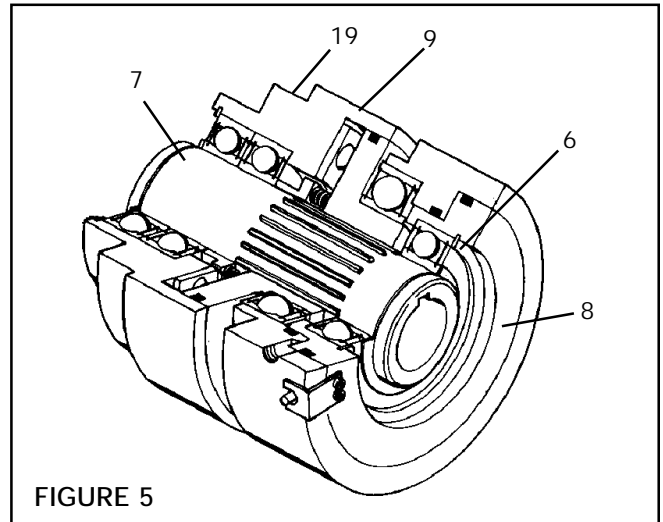

FIGURE 5

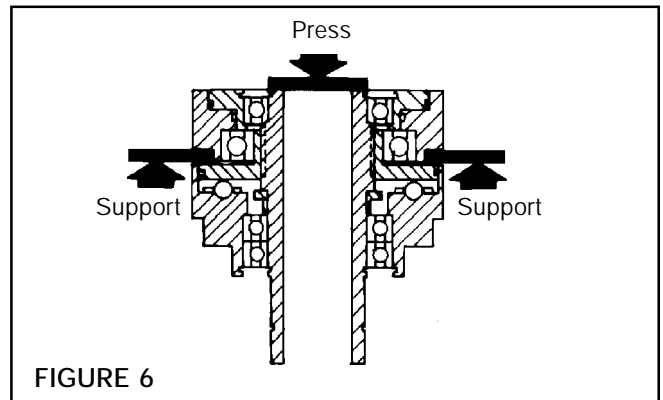

FIGURE 6

SPRING & STIFFENER PIN REPLACEMENT

1. Remove used Springs (Item 16) and Spring Stiffener Pins (Item 17) from Ring Drive (Item 10) (See Fig. 7).
2. Install new Stiffener Pins (Item 17) and Springs (Item 16) into Ring Drive (Item 10) (See Fig. 7).

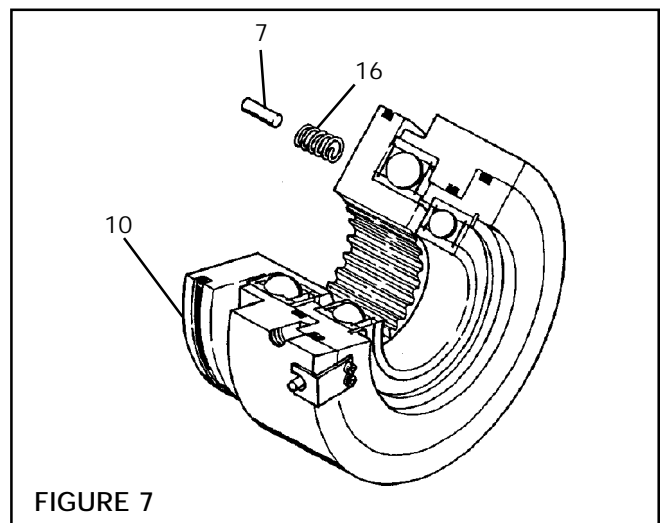

FIGURE 7

CYLINDER & PISTON BEARING REPLACEMENT

1. Separate Piston (Item 8) from Cylinder (Item 9) (See Fig. 8).
2. Remove Retaining Ring (Item 5) from Piston (Item 8) (See Fig. 8).
3. Fully supporting Piston (Item 8), press Bearing (Item 21) out of piston (See Figs. 8 & 9).
4. Clean bearing surface of piston with safety solvent.
5. Apply Loctite 601 or equivalent to outer race of new bearing and press new bearing into place.
6. Replace Retaining Ring (Item 5) (See Fig. 8).

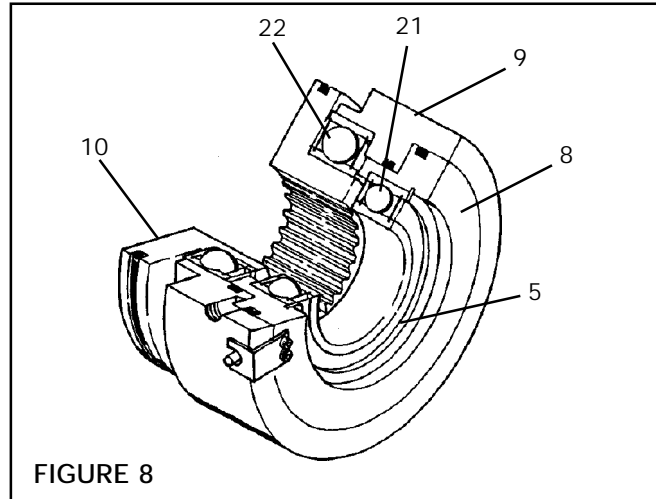

FIGURE 8

CAUTION
 When installing new bearings into Cylinder and/or Piston, carefully align bearing with bore of Cylinder and/or Piston.

7. Supporting Cylinder (Item 9), press Bearing (Item 22) and Ring Drive (Item 10) out of Cylinder (See Figs. 8 & 10)
8. Using a bearing puller, remove Bearing (Item 22) from Ring Drive (Item 10) (See Fig. 8).
9. Clean bearing surface of Cylinder with safety solvent.
10. Apply Loctite 601 pr equivalent to outer race of new bearing and press new bearing into Cylinder.
11. Press Ring Drive (Item 10) into Bearing (Item 22) and Cylinder (Item 9) (See Fig. 8).

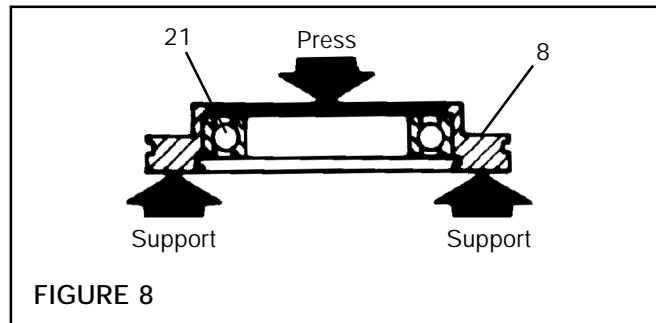

FIGURE 8

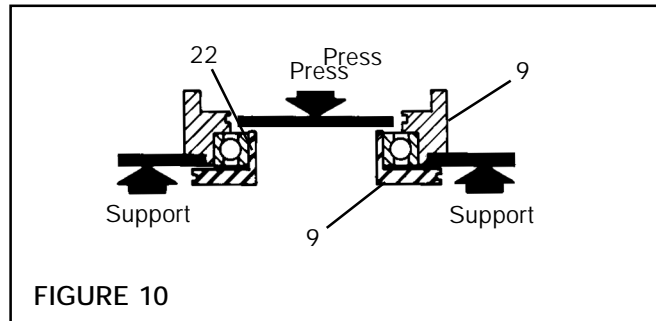

FIGURE 10

O-RING, ROTARY SEAL, & BACK-UP RING REPLACEMENT

1. Remove O-Rings (Items 12 & 13) and Back-Up Rings (Items 11 & 14) from Piston (Item 8) (See Fig. 11).
2. Clean o-ring grooves, then lubricate new O-rings and O-ring grooves of Piston with o-ring lubricant.
3. Install new O-Rings (Items 12 & 13) and Back-Up Rings (Items 11 & 14) (See Fig. 11).

NOTE: When installing new O-Rings and Back-Up Rings, make sure curved surface of Back-Up Ring matches surface of O-Ring. Back-Up Rings must be installed on the non-pressurized side of the O-Rings (See Fig. 12).

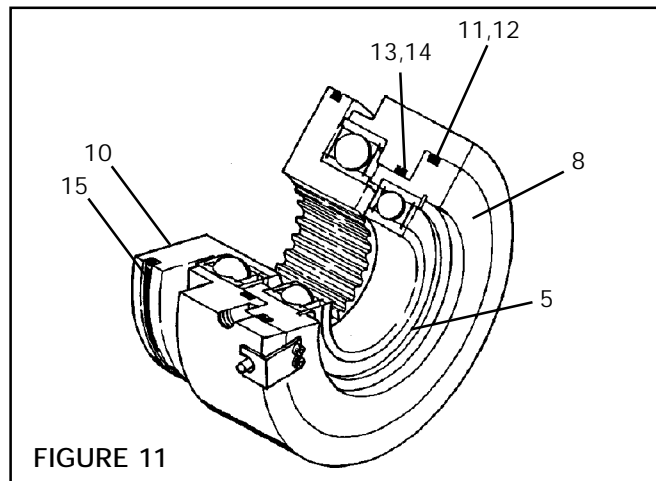
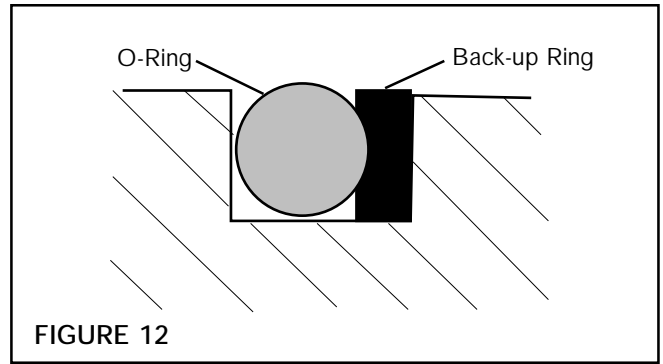

FIGURE 11

4. Remove Rotary Seal (Item 15) from Ring Drive (Item 10) (See Fig. 11).
5. Clean rotary seal groove, then lubricate new Rotary Seal and rotary seal groove of Ring Drive (Item 10) with O-ring lubricant and install new Rotary Seal (See Fig. 11).



DRIVE FLANGE BEARING REPLACEMENT

1. Remove Retaining Ring (Item 6) from Hub (Item 7) on Drive Flange end of Torque Limiter (See Fig. 13).
2. Supporting Drive Flange (Item 19) press Hub (Item 7) out of Drive Flange (See Fig. 14).
3. Remove Retaining Ring (Item 5) from Drive Flange (Item 19) (See Fig. 13).
4. Fully supporting Drive Flange (Item 19) press Bearings (Items 21) out of Drive Flange (See Fig. 15)
6. Clean bearing surface of Drive Flange with safety solvent.
7. Apply Loctite 601 or equivalent to outer race of new bearings, and press bearings into place.

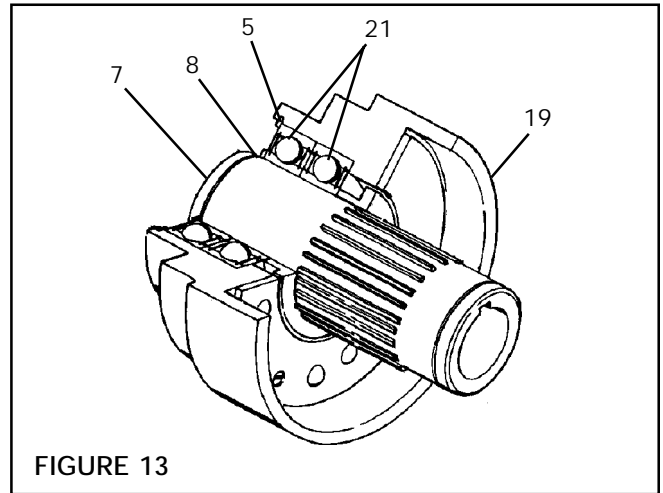

NOTE: Drive Flange Assembly consists of: Machine Screws, Ball Seat, Balls, and Drive Flange. If any of these items show signs of wear, or damage, entire Drive Flange Assembly (Item 19) must be replaced.

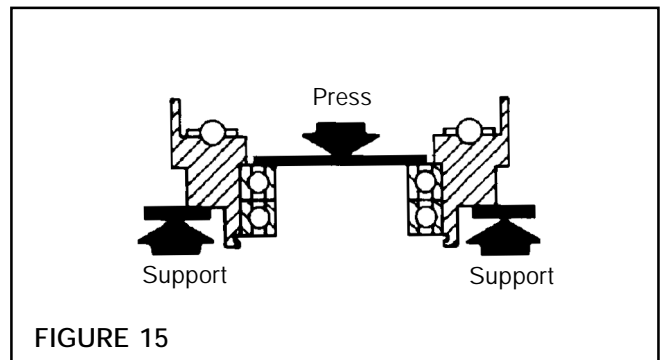
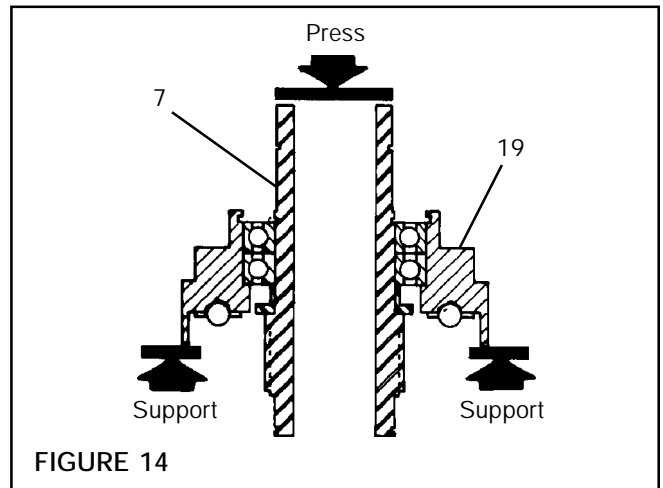

DC SERIES CLUTCH REASSEMBLY.

NOTE: In order to insure proper operation after reassembling the DC Series Clutch, align chalk alignment marks and line up Hub Keyway with Drive Ring Detents as shown (See Fig. 26).

1. Press Hub (Item 7) into Drive Flange Assembly (Item 19) (See Fig. 16).
2. Replace Retaining Ring (Item 6) on Drive Flange end of DC Series Clutch (See Fig. 16).
3. Install Springs (Item 17) and Spring Stiffener Pins (Item 16) into respective holes in Ring Drive (See Fig. 16).
4. Press Cylinder/Piston Assembly (Items 8 & 9) onto Hub (Item 7) (See Fig. 16).
5. Install Retaining Ring (Item 6) on Cylinder/Piston end of DC Series Clutch.

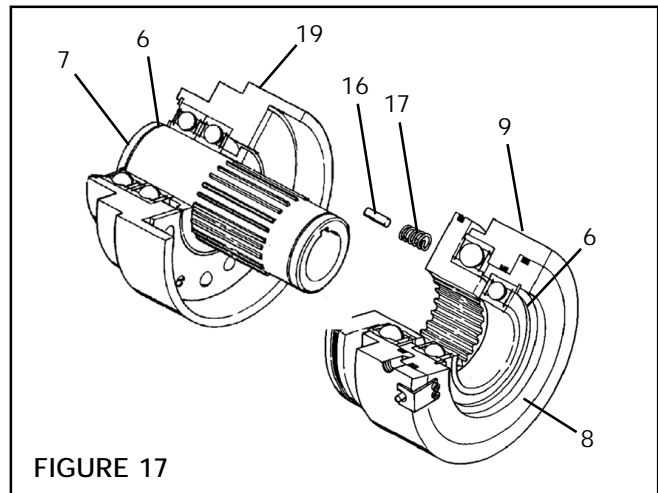
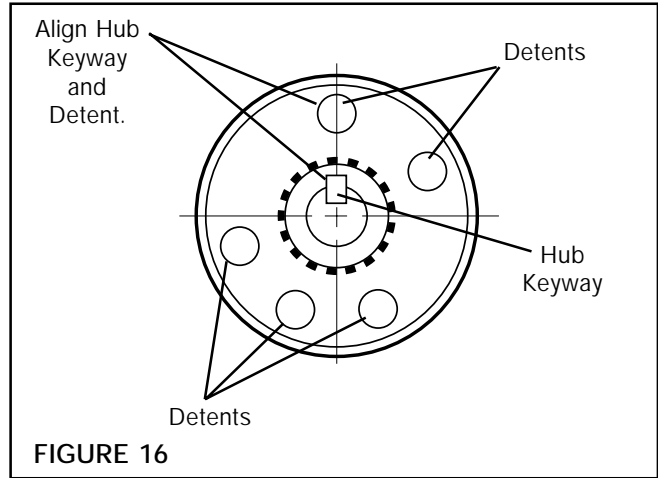

REPLACEMENT PARTS

The item or balloon number for all Nexen products is used for part identification on all product parts lists, product price lists, unit assembly drawings, bills of materials, and instruction manuals.

When ordering replacement parts, specify model designation, item number, part description, and quantity. Purchase replacement parts through your local Nexen Distributor.

REPAIR KITS

REPAIR KIT CONTENTS (all kits)

ITEM	DESCRIPTION
11	Back-Up Ring (large)
12	O-Ring (small)
13	O-Ring (small)
14	Back-Up Ring (small)
15	Rotary Seal
16	Pin, Spring Stiffener
17	Spring
21	Bearing
22	Bearing

REPAIR KIT NUMBERS

MODEL	REPAIR KIT NO.
DC10	801808
DC15	801808
DC20	801508
DC30	801518
DC40	801528
DC50	801538
DC60	801548
DC70	801558
DC80	801568

PARTS LIST

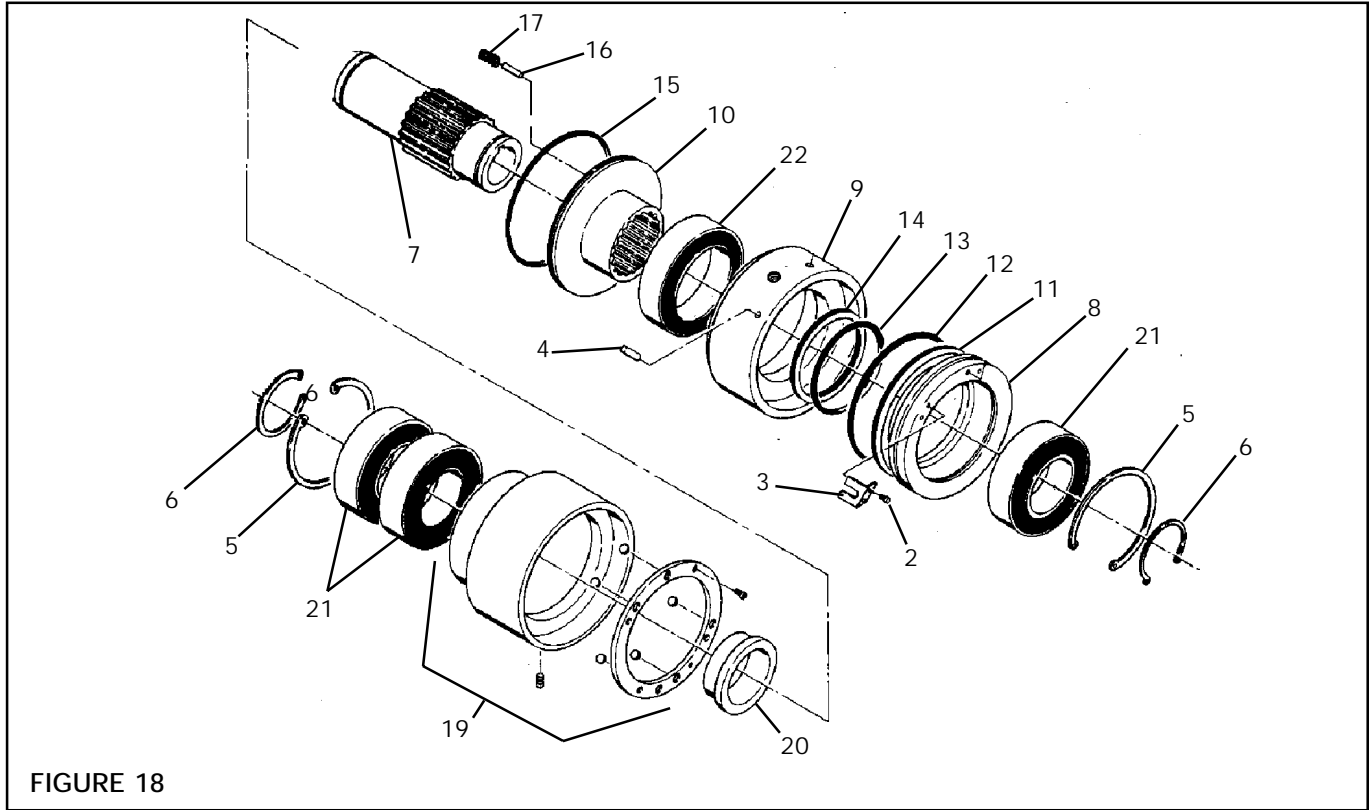

FIGURE 18

ITEM	DESCRIPTION	QUANTITY								
		DC10	DC15	DC20	DC30	DC40	DC50	DC60	DC70	DC80
1	Set Screw	2	2	3	3	3	3	3	3	3
2	Cap Screw	2	2	2	2	2	2	2	2	2
3	Anti-Rotation Clip	1	1	1	1	1	1	1	1	1
4	Anti-Rotation Pin	1	1	1	1	1	1	1	1	1
5	Retaining Ring	2	2	2	2	2	2	2	2	2
6	Retaining Ring	2	2	2	2	2	2	2	2	2
7	Hub	1	1	1	1	1	1	1	1	1
8	Piston	1	1	1	1	1	1	1	1	1
9	Cylinder	1	1	1	1	1	1	1	1	1
10	Ring Drive	1	1	1	1	1	1	1	1	1
11 ¹	Back-Up Ring (large)	1	1	1	1	1	1	1	1	1
12 ¹	O-Ring (large)	1	1	1	1	1	1	1	1	1
13 ¹	O-Ring (small)	1	1	1	1	1	1	1	1	1
14 ¹	Back-Up Ring (small)	1	1	1	1	1	1	1	1	1
15 ¹	Rotary Seal	1	1	1	1	1	1	1	1	1
16 ¹	Pin, Spring Stiffener	3	3	6	10	13	15	18	20	21
17 ¹	Spring	3	3	6	10	13	15	18	20	21
19 ¹	Drive Flange Assembly	1	1	1	1	1	1	1	1	1
20	Backing Plate	1	1	1	1	1	1	1	1	1
21 ¹	Bearing	3	3	3	3	3	3	3	3	3
22 ¹	Bearing	1	1	1	1	1	1	1	1	1
24	Air Line (not shown)	1	1	1	1	1	1	1	1	1

¹ Denotes Repair Kit Item.

² Drive Flange Assembly (Item 19) includes; Drive Flange, Machine Screws, Ball Seat, Balls, and Vent Plug.

AIR CHAMP[®] PRODUCTS

User Manual

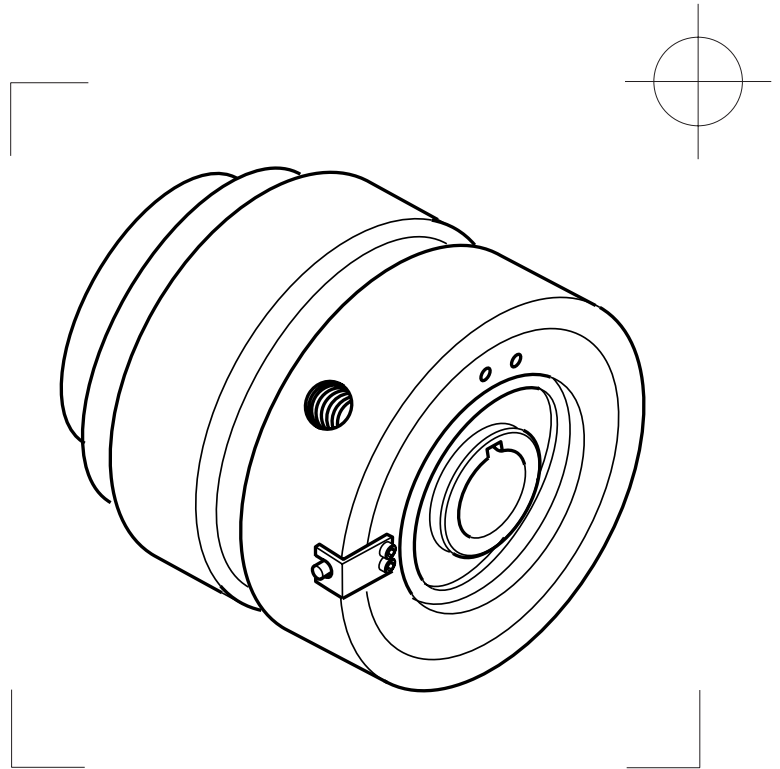

Single-Position Detent Clutch DC Series

In accordance with Nexen's established policy of constant product improvement, the specifications contained in this manual are subject to change without notice. Technical data listed in this manual are based on the latest information available at the time of printing and are also subject to change without notice.

Technical Support:
800-843-7445
(651) 484-5900

www.nexengroup.com



WARNING

Read this manual carefully before installation and operation.

Follow Nexen's instructions and integrate this unit into your system with care.

This unit should be installed, operated and maintained by qualified personnel ONLY.

Improper installation can damage your system or cause injury or death.

Comply with all applicable codes.

Nexen Group, Inc.
560 Oak Grove Parkway
Vadnais Heights, Minnesota 55127

TABLE OF CONTENTS

Introduction ----- 1

Hub Preparation ----- 2

Installation ----- 3

Air Connections ----- 4

Lubrication ----- 4

Operation ----- 5

Parts Replacement ----- 6

Replacement Parts ----- 9

Repair Kits ----- 9

Parts List ----- 10

Warranties ----- 11

WARRANTIES

Warranties

Nexen warrants that the Products will be free from any defects in material or workmanship for a period of 12 months from the date of shipment. NEXEN MAKES NO OTHER WARRANTY, EXPRESS OR IMPLIED, AND ALL IMPLIED WARRANTIES, INCLUDING WITHOUT LIMITATION, IMPLIED WARRANTIES OF MERCHANTABILITY AND FITNESS FOR A PARTICULAR PURPOSE ARE HEREBY DISCLAIMED. This warranty applies only if (a) the Product has been installed, used and maintained in accordance with any applicable Nexen installation or maintenance manual for the Product; (b) the alleged defect is not attributable to normal wear and tear; (c) the Product has not been altered, misused or used for purposes other than those for which it was intended; and (d) Buyer has given written notice of the alleged defect to Nexen, and delivered the allegedly defective Product to Nexen, within one year of the date of shipment.

Exclusive Remedy

The exclusive remedy of the Buyer for any breach of the warranties set out above will be, at the sole discretion of Nexen, a repair or replacement with new, serviceably used or reconditioned Product, or issuance of credit in the amount of the purchase price paid to Nexen by the Buyer for the Products.

Limitation of Nexen's Liability

TO THE EXTENT PERMITTED BY LAW NEXEN SHALL HAVE NO LIABILITY TO BUYER OR ANY OTHER PERSON FOR INCIDENTAL DAMAGES, SPECIAL DAMAGES, CONSEQUENTIAL DAMAGES OR OTHER DAMAGES OF ANY KIND OR NATURE WHATSOEVER, WHETHER ARISING OUT OF BREACH OF WARRANTY OR OTHER BREACH OF CONTRACT, NEGLIGENCE OR OTHER TORT, OR OTHERWISE, EVEN IF NEXEN SHALL HAVE BEEN ADVISED OF THE POSSIBILITY OR LIKELIHOOD OF SUCH POTENTIAL LOSS OR DAMAGE. For all of the purposes hereof, the term "consequential damages" shall include lost profits, penalties, delay images, liquidated damages or other damages and liabilities which Buyer shall be obligated to pay or which Buyer may incur based upon, related to or arising out of its contracts with its customers or other third parties. In no event shall Nexen be liable for any amount of damages in excess of amounts paid by Buyer for Products or services as to which a breach of contract has been determined to exist. The parties expressly agree that the price for the Products and the services was determined in consideration of the limitation on damages set forth herein and such limitation has been specifically bargained for and constitutes an agreed allocation of risk which shall survive the determination of any court of competent jurisdiction that any remedy herein fails of its essential purpose.

Limitation of Damages

In no event shall Nexen be liable for any consequential, indirect, incidental, or special damages of any nature whatsoever, including without limitation, lost profits arising from the sale or use of the Products.

Warranty Claim Procedures

To make a claim under this warranty, the claimant must give written notice of the alleged defect to whom the Product was purchased from and deliver the Product to same within one year of the date on which the alleged defect first became apparent.

nexen[®]

Nexen Group, Inc.
560 Oak Grove Parkway
Vadnais Heights, MN 55127

800.843.7445
Fax: 651.286.1099
www.nexengroup.com

ISO 9001 Certified