

WEB CONTROL PRODUCTS

User Manual

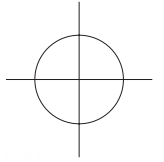

TCD 030 Open Loop Tension Controller

In accordance with Nexen's established policy of constant product improvement, the specifications contained in this manual are subject to change without notice. Technical data listed in this manual are based on the latest information available at the time of printing and are also subject to change without notice.

Technical Support:
800-843-7445
(651) 484-5900

www.nexengroup.com



WARNING

Read this manual carefully before installation and operation.

Follow Nexen's instructions and integrate this unit into your system with care.

This unit should be installed, operated and maintained by qualified personnel ONLY.

Improper installation can damage your system or cause injury or death.

Comply with all applicable codes.

Nexen Group, Inc.
560 Oak Grove Parkway
Vadnais Heights, Minnesota 55127

TABLE OF CONTENTS

Introduction ----- 1

Installation ----- 2

Electrical Connections ----- 4

Calibration ----- 5

Operation ----- 6

Specifications ----- 7

Parts List ----- 7

Mounting Dimensions ----- 8

Warranties ----- 9

INTRODUCTION

Read this manual carefully, making full use of its explanations and instructions. The “Know How” of safe, continuous, trouble-free operation depends on the degree of your understanding of the system and your willingness to keep all components in proper operating condition. Pay particular attention to all NOTES, CAUTIONS, and WARNINGS to avoid the risk of personal injury or property damage. It is important to understand that these NOTES, CAUTIONS, and WARNINGS are not exhaustive. Nexen cannot possibly know or evaluate all conceivable methods in which service may be performed, or the possible hazardous consequences of each method. Accordingly, anyone who uses a procedure that is not recommended by Nexen must first satisfy themselves that neither their safety or the safety of the product will be jeopardized by the service method selected.

Nexen’s TCD 030 tension control system has been designed to maintain constant tension in a web at the unwind or rewind position. TCD 030 is a total non-contact type system, composed of the TCD 030, a Proximity Switch, and Output Amplifier.

The Output Amplifier can be an EN40 type Electro-Pneumatic Converter to convert the 4-20mA output of the TCD 030 into a variable air pressure for control of an air operated clutch or brake. The Output Amplifier may also be an electrical power supply (i.e., Nexen’s MPB Power Supply) to follow 0-10V output from TCD 030 and modulate output to an electrical brake or clutch.

In automatic operation, the operator enters the initial roll radius (full roll for an unwind, core for wind up), web thickness, and tension set point. The Tension Controller calculates the correct output to the Output Amplifier based upon the set point and radius. As the roll builds up on a wind up, the Tension Controller adds one web thickness to the roll radius every time the Proximity Switch indicates one revolution. On an unwind, it subtracts one thickness for each revolution.

INSTALLATION

PREPARATION

1. Remove two Phillips head screws from top cover and remove the cover.
2. Set Voltage Jumper Wire to correspond to AC Voltage supplied to TCD 030. Select from 100, 110, 200, or 220VAC (See Figure 1).
3. On the metric model, set SW1 for "m" or "μ". This determines the value of numbers entered in the "t" or Thickness Rotary Switch located on the front panel. The selection of "m" indicates the values will be 0.01-9.99 millimeters. The selection μ resets the values on the "t" Switch to the range of 1-999 microns (μm). On the Inch model, set SW1 Switch to μ. (See Figure 2).
4. Set SW2 to W for wind up clutch control or UW for unwind control (See Figure 2).
5. Replace the top cover and reinstall the two Phillips head screws.

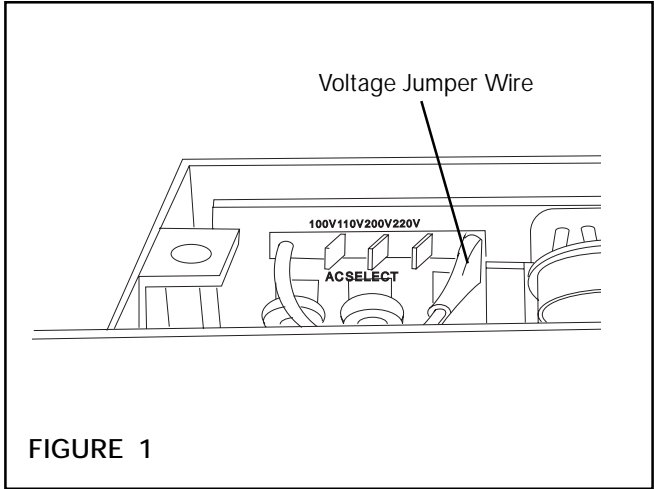

FIGURE 1

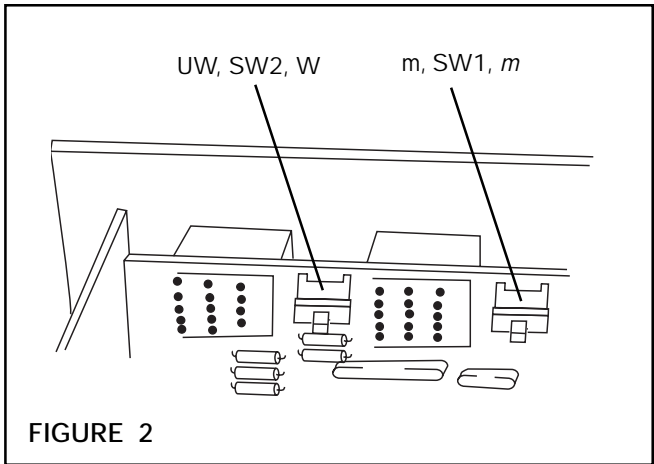

FIGURE 2

POSITIONING

The TCD 030 is designed for easy panel mounting. Refer to MOUNTING DIMENSIONS for dimensions, hole sizes, and panel cut out dimensions (See Figure 7).

NOTE: The TCD 030 is an electronic component and should be mounted in a shock and vibration free area which has an ambient temperature of more than 32° F [0° C] and less than 122° F [50° C]

PROXIMITY SWITCH MOUNTING

1. The Proximity Switch senses a customer supplied ferrous metal (iron or steel) target. The minimum gap between the Proximity Switch and the target is 0.20 inches [5 mm] and maximum gap is 0.40 inches [10 mm]. The target must be of sufficient mass to trigger the Proximity Switch and may be mounted to the roll shaft or any other mechanical component which rotates at the same speed as the roll shaft, brake, rotor, etc. (See Figure 3).
2. Mount Proximity Switch to a non-rotating member using mounting bracket provided (See Figure 15, Page 10).

NOTE: The Proximity Switch must be mounted in such a position as to maintain the correct gap as defined in Step 1.

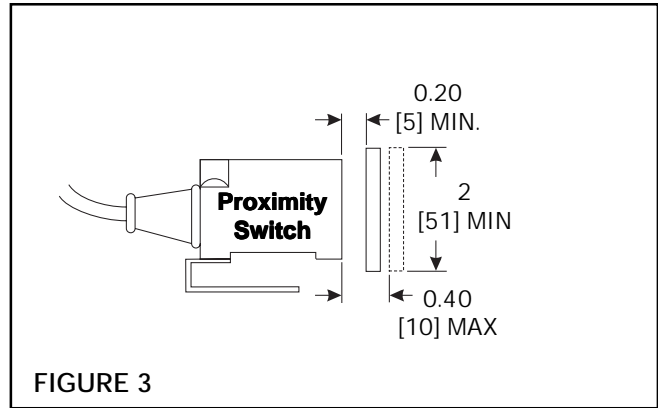

FIGURE 3

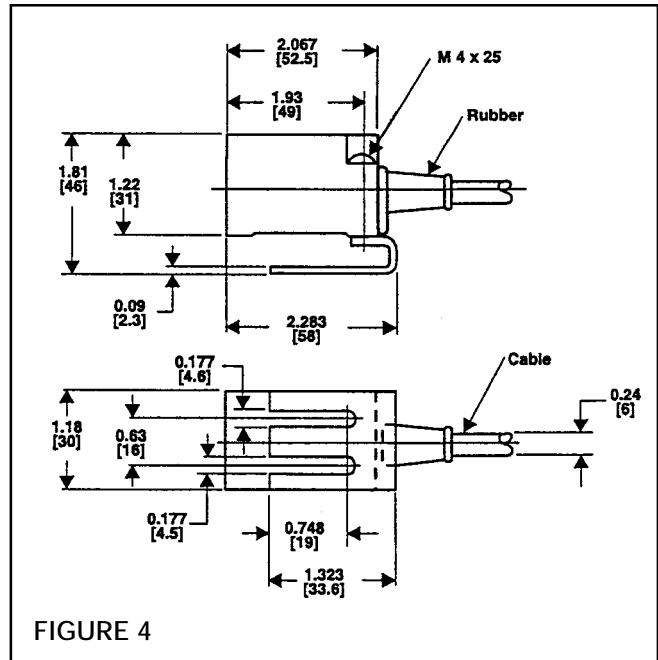

FIGURE 4

ELECTRICAL CONNECTIONS

WARNING

All wiring must be shielded or run through conduit. Wire runs are to be no more than 300 feet. Connect all wires to terminal strip on back panel of TCD 030 (See Figure 4).

The **Remote Start Switch** is optional, customer provided, and momentary contact. A Remote Start Switch is built into the TCD 030 front panel.

The optional **Stop Switch** is also customer provided with maintained contact. Use with the unwind brake only.

For the **Proximity Switch**, use Horton Part Number 912068.

Wire the Proximity Switch to Terminals 5, 6, and 7.

1. Positive voltage wire (Brown) to Terminal 5.
2. Signal wire (Black) to Terminal 6.
3. Common wire (Blue) to Terminal 7.

Terminals 9 and 10 provide a 0-10V control signal for output to a remote power supply to control an electric clutch or brake.

Terminals 11 and 12 provide a 4-20mA signal which is used to control an EN40 Electro-Pneumatic Converter when a pneumatic control signal is needed for an air brake or clutch.

WARNING

Observe polarity when connecting the EN40 to the TCD 030.

Connect AC power rated 100, 200, or 220VAC, at 50 or 60 Hz, single phase to Terminals 13 and 14, with ground to Terminal 15.

NOTE: Be sure Voltage Jumper Wire is connected for correct voltage (See **INSTALLATION**).

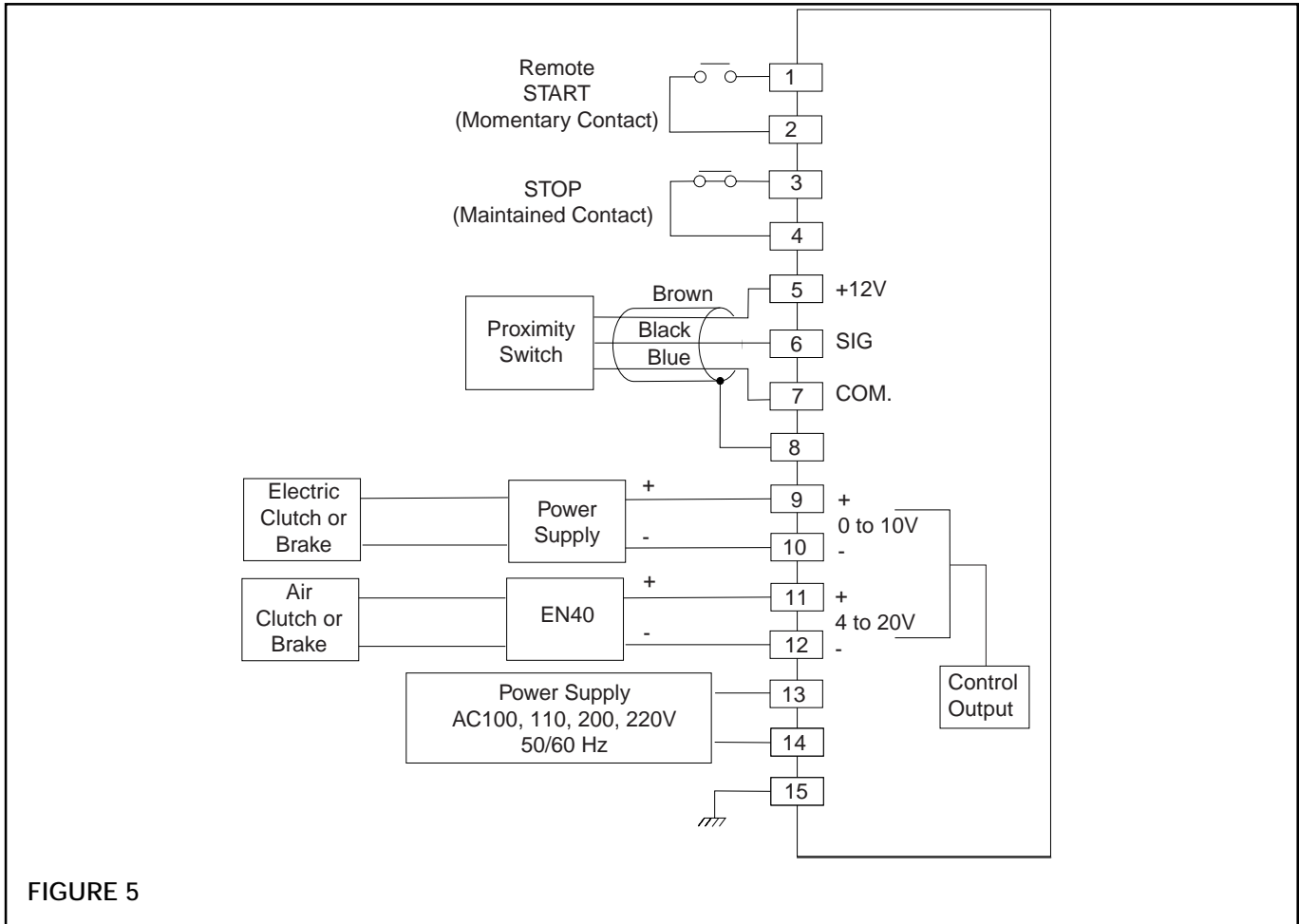

FIGURE 5

CALIBRATION

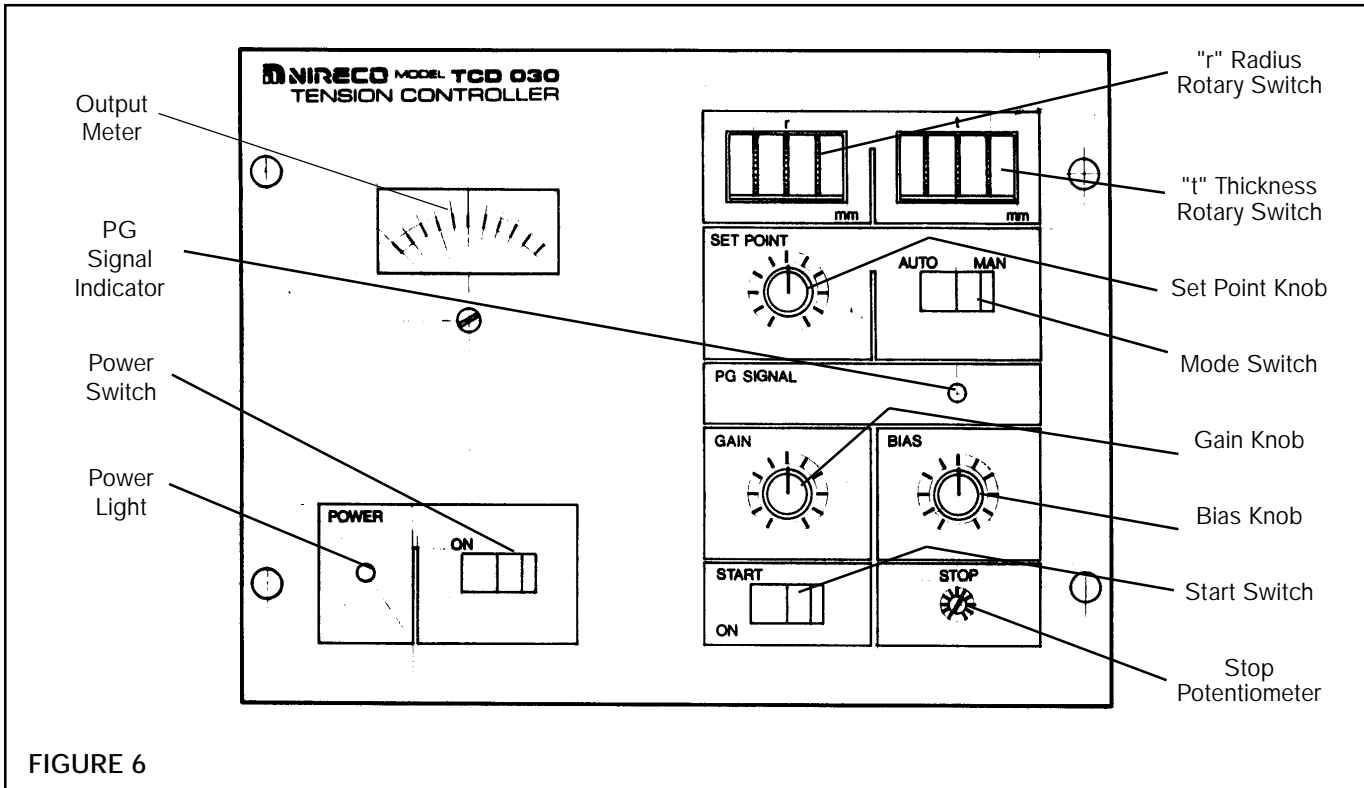

FIGURE 6

1. Set Mode Switch to **AUTO** (See Figure 5).

The optional, customer supplied **Stop Switch** is used with an unwind brake to increase brake torque during a stop, to prevent coasting, and web spillage.

The additional braking effort is adjustable from one to three times the running torque with the **STOP** Potentiometer located on the TCD 030 front panel. Stop torque is maintained as long as the Stop Switch is held in the closed position.

NOTE: The Stop Switch is not used for clutch control of a wind up.

2. Perform initial set up.

This operation must be performed when first placing TCD 030 into service. It calibrates the TCD 030 to deliver 100 percent output when the wind up or unwind roll is at maximum radius and the Set Point Knob is at maximum.

- a. Rotate **GAIN** Knob counterclockwise for minimum setting (See Figure 5).
- b. Rotate **BIAS** Knob to mid-position setting (See Figure 5).

- c. Determine the maximum roll radius to be run on the machine.
- d. Select (in inches or millimeters) the maximum roll radius on the "**r**" Radius Rotary Switch.
- e. Rotate the Set Point Knob clockwise to maximum.
- f. Press the Start Switch (either the built in start switch or the remote switch).
- g. Adjust **GAIN** Knob so that the Output Meter indicates 100 percent.

NOTE: The Start Switch is a momentary contact switch; therefore, it will not stay depressed.

NOTE: 100 percent can not be achieved with a maximum roll radius of 7 inches [180 millimeters] or less.

This completes calibration of the TCD 030. If the maximum roll radius to be run on the machine increases, the TCD 030 must be recalibrated. If 100 percent output is desired at a smaller radius, the TCD 030 must also be recalibrated to that size.

OPERATION

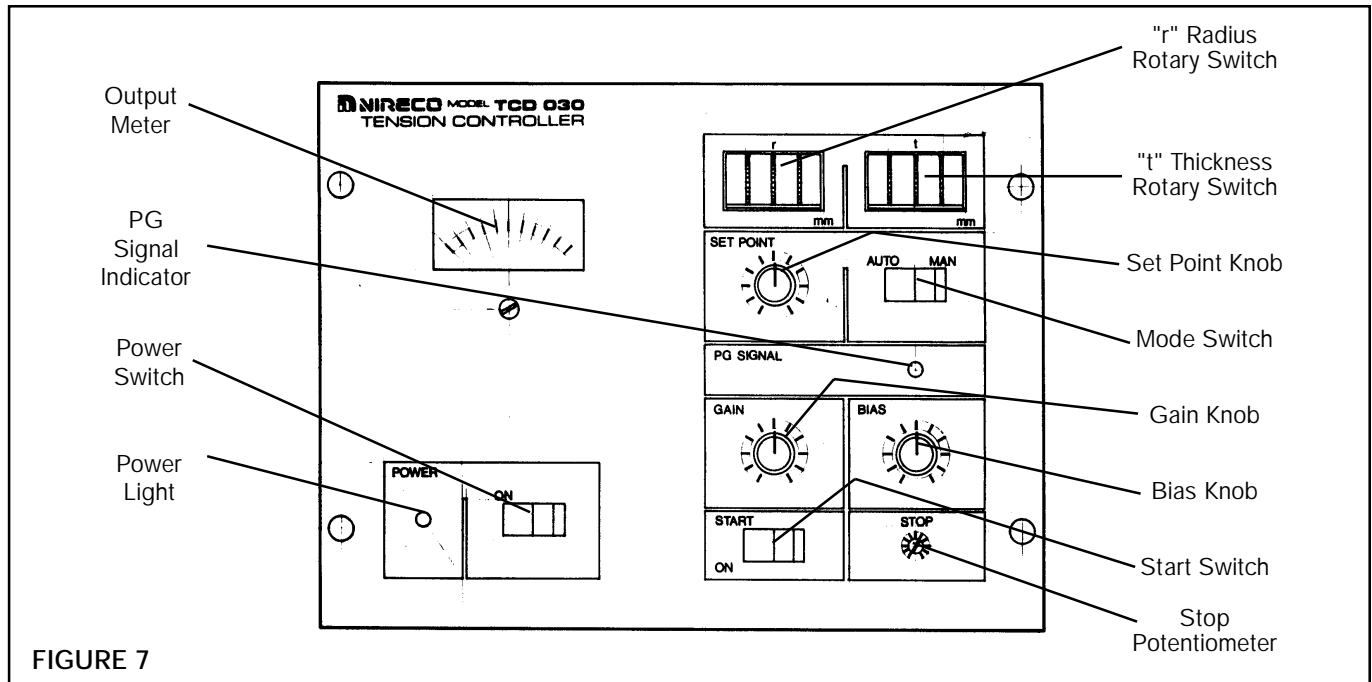

FIGURE 7

MANUAL OPERATION

1. Set Mode Switch to **MAN** (See Figure 6).
 2. Set Point Knob controls Output from 0-100 percent (rotate clockwise to increase and counterclockwise to decrease).
- NOTE: 0-100 percent is equal to 0-10VDC or 4-20mA, depending on which output terminals have been selected.
4. Rotate Set Point Knob counterclockwise to minimum setting.
 5. Set GAIN Knob to calibration position as determined in **CALIBRATION**.
 6. Set the BIAS Knob to middle position (straight up).
 7. Start the machine.
 8. Press the Start Switch (either built in switch on TCD 030 front panel or the remote switch) (See **ELECTRICAL CONNECTIONS**).

UNWIND BRAKE CONTROL

1. Set Mode Switch to **AUTO** (See Figure 6).
 2. Dial full roll radius into the "r" Radius Rotary Switch. This value is expressed in inches or millimeters.
 3. Dial web thickness into the "t" Thickness Rotary Switch. This value expressed in inches or millimeters.
- NOTE: If the m position was selected, the "t" value is expressed as 1-999 microns (m meters).
- The Inch model of the TCD 030 is calibrated to accept thickness settings of 0.0005-0.0999 inches.
- The Metric model can be calibrated to accept thickness settings of 0.01-9.99 mm or 1-999 microns (See **INSTALLATION**).
9. Rotate Set Point Knob clockwise until desired web tension is reached.
 10. Observe operation of the first roll.
 - a. If tension is correct at the beginning of the unwind and becomes slack as the radius decreases, rotate the Bias Knob clockwise to raise the tension back up to the desired level.
 - b. If tension becomes greater as the roll decreases in radius, rotate the Bias Knob counterclockwise until tension drops to the desired level.
 11. When roll is depleted, press and hold the Stop Button until unwind roll has stopped.
 12. Dial the roll radius of the next roll into the "r" Switch, also change the "t" value if the web is a different thickness.

WIND UP CLUTCH CONTROL

1. Set Mode Switch to **AUTO**.
 2. Dial the core radius into the "r" Radius Rotary Switch. This value is expressed in inches or millimeters.
 3. Dial the web thickness into the "t" Thickness Rotary Switch. This value is expressed in inches or millimeters.
- NOTE: If the "μ" position was selected, the "t" value is expressed as 1-999 microns (μ meters).
4. Rotate Set Point Knob counterclockwise (minimum setting).
 5. Rotate Gain Knob to calibrated position as determined in **CALIBRATION**.
 6. Rotate Bias Knob to middle position (straight up).
 7. Start the machine.
 8. Press the Start Switch, either the built in switch on TCD 030 front panel or the remote switch (See **ELECTRICAL CONNECTIONS**).
 9. Rotate Set Point Knob clockwise until the desired web tension is reached.
 10. Observe operation of the first roll.
 - a. If tension at the core is correct, but tends to become slack, rotate the BIAS Knob clockwise.
 - b. If the tension is correct at the core but becomes tighter as the radius increases, rotate the GAIN Knob counterclockwise.
 11. Core radius value "r" must be changed if a new core size is used.
 12. Web thickness value "t" must be changed when a new web of different thickness is run.
 13. Taper tension can be achieved by slightly decreasing the "t" value or BIAS Knob setting.

SPECIFICATIONS

TCD 030

Control Output.....	0-10VDC 4-20mA
Constant Rating (Start and Stop Switches).....	DC15V, 30mA
Input.....	"0"...0-1VDC (10mA) "1".....10-12VDC
12V System Rectangular Wave; One pulse per revolution of the wind or unwind roll.	
AC Power.....	100, 110, 200, 220VAC
Power Consumption.....	5VA
Ambient Temperature.....	32°-120° F (0°-50° C)
Weight.....	3.75 Lbs. [1.7 kg]

PROXIMITY SWITCH

Supply Voltage.....	10-30VDC
Power Consumption.....	≤10mA
Output Signal.....	"0" ...≤1VDC (10mA) "1"≥10VDC
Frequency Response.....	≥50 Hz

PARTS LIST

Main PC Board.....	3085
Power Supply PC Board.....	3086
Digital Switch.....	3088
Output Meter.....	3089
Potentiometer.....	3090

MOUNTING DIMENSIONS

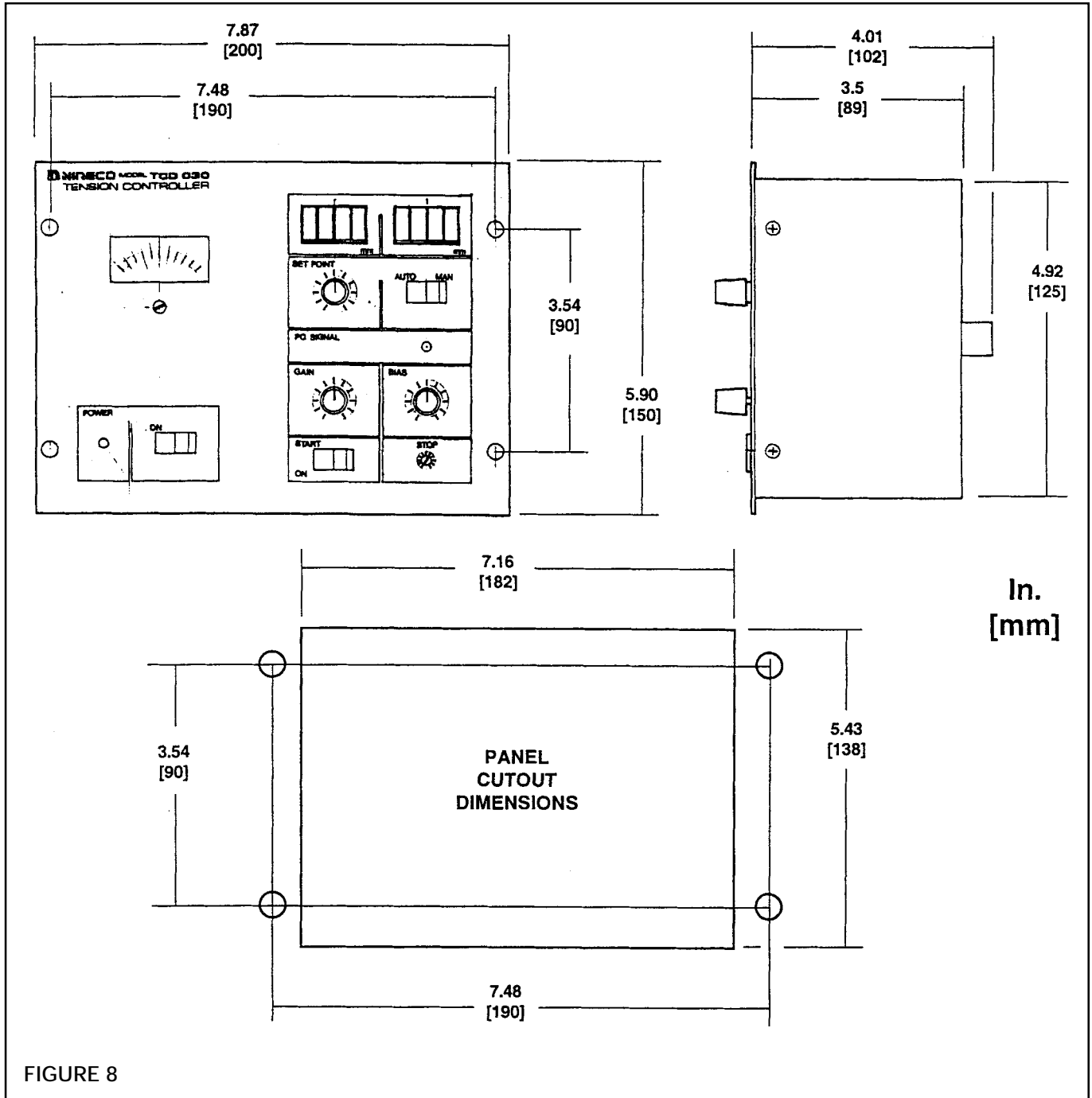

FIGURE 8



WARRANTIES

Warranties

Nexen warrants that the Products will be free from any defects in material or workmanship for a period of 12 months from the date of shipment. NEXEN MAKES NO OTHER WARRANTY, EXPRESS OR IMPLIED, AND ALL IMPLIED WARRANTIES, INCLUDING WITHOUT LIMITATION, IMPLIED WARRANTIES OF MERCHANTABILITY AND FITNESS FOR A PARTICULAR PURPOSE ARE HEREBY DISCLAIMED. This warranty applies only if (a) the Product has been installed, used and maintained in accordance with any applicable Nexen installation or maintenance manual for the Product; (b) the alleged defect is not attributable to normal wear and tear; (c) the Product has not been altered, misused or used for purposes other than those for which it was intended; and (d) Buyer has given written notice of the alleged defect to Nexen, and delivered the allegedly defective Product to Nexen, within one year of the date of shipment.

Exclusive Remedy

The exclusive remedy of the Buyer for any breach of the warranties set out above will be, at the sole discretion of Nexen, a repair or replacement with new, serviceably used or reconditioned Product, or issuance of credit in the amount of the purchase price paid to Nexen by the Buyer for the Products.

Limitation of Nexen's Liability

TO THE EXTENT PERMITTED BY LAW NEXEN SHALL HAVE NO LIABILITY TO BUYER OR ANY OTHER PERSON FOR INCIDENTAL DAMAGES, SPECIAL DAMAGES, CONSEQUENTIAL DAMAGES OR OTHER DAMAGES OF ANY KIND OR NATURE WHATSOEVER, WHETHER ARISING OUT OF BREACH OF WARRANTY OR OTHER BREACH OF CONTRACT, NEGLIGENCE OR OTHER TORT, OR OTHERWISE, EVEN IF NEXEN SHALL HAVE BEEN ADVISED OF THE POSSIBILITY OR LIKELIHOOD OF SUCH POTENTIAL LOSS OR DAMAGE. For all of the purposes hereof, the term "consequential damages" shall include lost profits, penalties, delay images, liquidated damages or other damages and liabilities which Buyer shall be obligated to pay or which Buyer may incur based upon, related to or arising out of its contracts with its customers or other third parties. In no event shall Nexen be liable for any amount of damages in excess of amounts paid by Buyer for Products or services as to which a breach of contract has been determined to exist. The parties expressly agree that the price for the Products and the services was determined in consideration of the limitation on damages set forth herein and such limitation has been specifically bargained for and constitutes an agreed allocation of risk which shall survive the determination of any court of competent jurisdiction that any remedy herein fails of its essential purpose.

Limitation of Damages

In no event shall Nexen be liable for any consequential, indirect, incidental, or special damages of any nature whatsoever, including without limitation, lost profits arising from the sale or use of the Products.

Warranty Claim Procedures

To make a claim under this warranty, the claimant must give written notice of the alleged defect to whom the Product was purchased from and deliver the Product to same within one year of the date on which the alleged defect first became apparent.

nexen[®]

Nexen Group, Inc.
560 Oak Grove Parkway
Vadnais Heights, MN 55127

800.843.7445
Fax: 651.286.1099
www.nexengroup.com

ISO 9001 Certified