

AIR CHAMP® PRODUCTS

User Manual

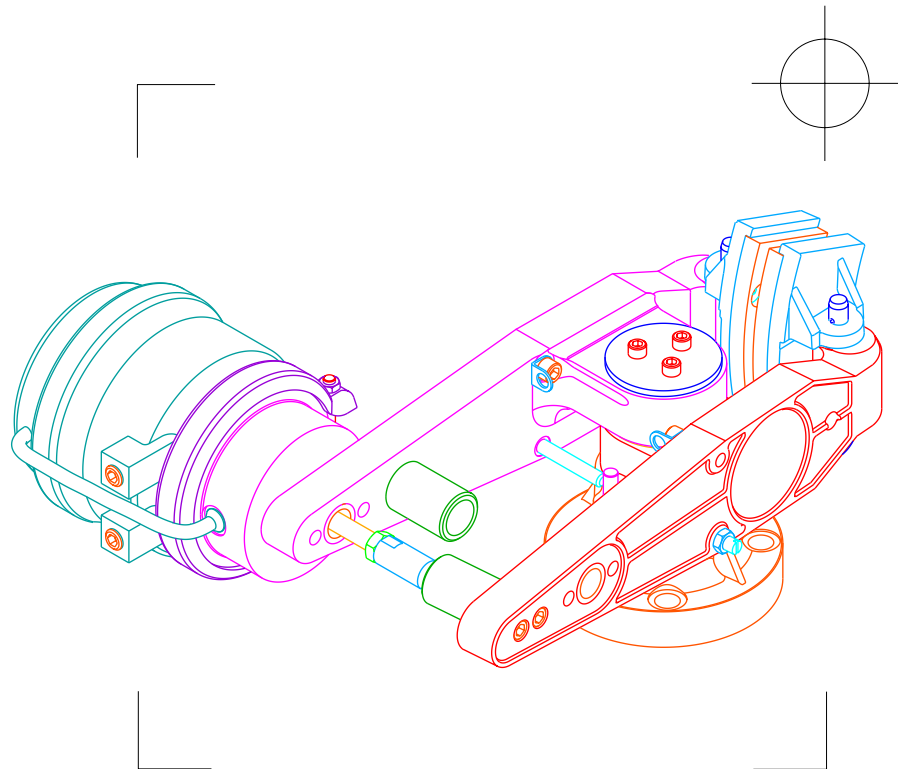

Single Post Caliper Brakes

Visit www.nexengroup.com for translations of this user manual.

Visite www.nexengroup.com para ver traducciones de este manual del usuario.

Consulter www.nexengroup.com pour toute traduction de ce présent manuel.

Besuchen Sie bitte www.nexengroup.com für die Übersetzung dieser Gebrauchsanweisung.

In accordance with Nexen's established policy of constant product improvement, the specifications contained in this manual are subject to change without notice. Technical data listed in this manual are based on the latest information available at the time of printing and are also subject to change without notice.

Technical Support: 800-843-7445
(651) 484-5900

www.nexengroup.com

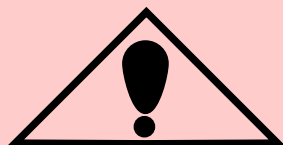

DANGER

Read this manual carefully before installation and operation.

Follow Nexen's instructions and integrate this unit into your system with care.

This unit should be installed, operated and maintained by qualified personnel **ONLY**.

Improper installation can damage your system or cause injury or death.

Comply with all applicable codes.

Nexen Group, Inc.
560 Oak Grove Parkway
Vadnais Heights, Minnesota 55127

ISO 9001 Certified

Table of Contents

Indroduction	4
Installation	5
Friction Facing Adjustment	7
Air Connections	8
Lubrication.....	9
Operational Modes	10
Maintenance	11
Parts Replacement	12
Replacement Parts	13
Parts List	14
Warranty	16

INTRODUCTION

BEFORE YOU BEGIN

Nexen has introduced a new actuator for SPC Caliper Brake spring-engaged models. The old Three-Port Actuator is obsolete.

The new actuator is geometrically different and the manual disengagement mechanism operates differently. The redesigned two-port model has a rubber hose on the exterior of the product used for balancing internal air pressure. The service and spring ports for this model have been redesigned and simplified.

The mounting procedures on both actuators are identical.

Review the summary of actuator differences below before beginning any installation or maintenance procedures.

NOTE: The installation and maintenance procedures for each model are located next to each other in this manual. Be sure to follow the appropriate instructions for each model.

SUMMARY OF DIFFERENCES IN SPC ACTUATORS

	Two-Port Acuator	Obsolete Three-Port Actuator
Overall Length	169 mm [6.67 in]	214 mm [8.41 in]
Diameter	163 mm [6.44 inches]	160 mm [6.31 inches]
Clamping Force	5% greater	refer to catalog data
Hold-Off Pressure	5.10 bar [74 psi]	4.96 bar [72 psi]
Power Spring	Non-coil clash	Telescoping
Ports	One spring release and one plugged port	One spring release and two plugged ports

INSTALLATION

DISC

1. Thoroughly inspect the tapered bore of the Disc Hub and tapered surface of the Q.D. Bushing. Remove any dirt, grease, or foreign material. Do not use lubricants for this installation.
2. Assemble the Q.D. Bushing into the Disc Hub, aligning the untapped holes in the Bushing Flange with the tapped holes in the disc hub.
3. Insert the pull-up bolts and tighten to the recommended torque (See Tables 1 and 2).

NOTE: Runout is minimized if a Dial Indicator is used as the Pull-up Bolts are tightened. Place contact tip of the Dial Indicator on the machined surface of the Rotor to measure runout. Runout should be less than 0.254-0.381 mm [0.010-0.015 inches] (See Figure 1).

CAUTION

If excessive tightening torque is applied, bursting pressures are created in the hub. There must be a gap between the flange of the Q.D. bushing and the disc hub to ensure a proper fit of the Q.D. bushing onto the shaft.

4. To remove the Q.D. bushing, remove the pull-up bolts and reinsert into the threaded holes. Tighten the pull-up bolts to push the disc off the Q.D. bushing.

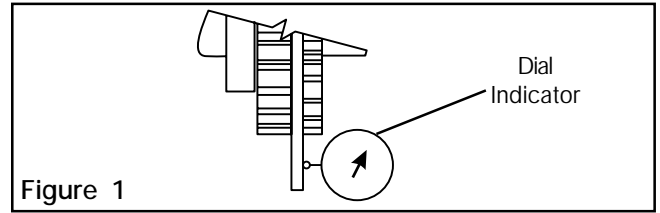

Table 1 (Non-Ventilated Discs)

DIAMETER mm [inches]	PRODUCT NO.	QD BUSHING	TORQUE Nm [ft-lb]
305 [12]	934201	SF	40.5 [30]
356 [14]	934202	E	81 [60]
406 [16]	934203	E	81 [60]
457 [18]	934204	J	182.5 [135]
508 [20]	934205	J	182.5 [135]
559 [22]	934206	J	182.5 [135]
610 [24]	934207	J	182.5 [135]

Table 2 (Ventilated Discs)

DIAMETER mm [inches]	PRODUCT NO.	QD BUSHING	TORQUE Nm [ft-lb]
464 [18.25]	934200	J	182.5 [135]
533 [21]	934300	J	182.5 [135]
610 [24]	934400	J	182.5 [135]

ACTUATOR

NOTE: The Spring Actuator Assembly and the Air Actuator Assembly are sold separately. One or two Actuators can be installed on the SPC Brake. When one Actuator is used, the brake torque will be higher if the Actuator is mounted on the High Torque Arm (Item 4). When two Actuators are used on the SPC Brake, both Actuators must be of the same type.

SPRING ACTUATOR

1. Insert the Rod (Item 43), Jam Nut (Item 31), and Spacer (Item 32) into the Actuator (See Figure 2).

NOTE: Mount this assembly on either the Low Torque Arm (Item 3) or the High Torque Arm (Item 4) (See Figure 2).

2. Install the Cap Screws (Item 33) and the Lock Washers (Item 34) (See Figure 2).
3. Tighten the Cap Screws (Item 33) to 64.5 Nm [48 ft-lb] torque.

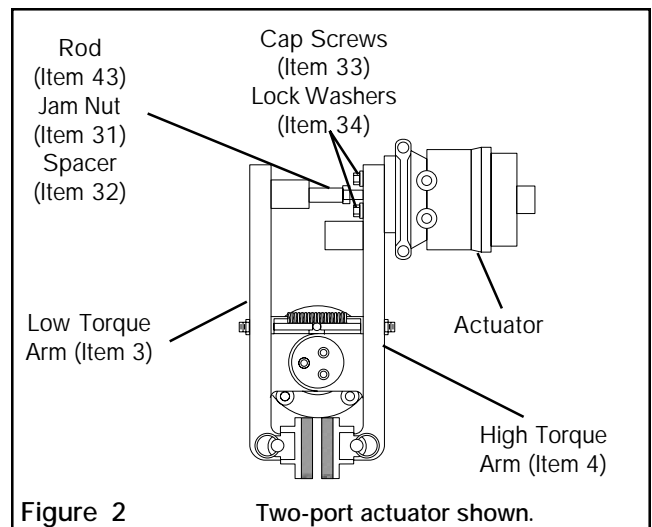

AIR ACTUATOR

1. Insert the Rod (Item 30), Jam Nut (Item 31), and Spacer (Item 32) into the Actuator (See Figure 3).

NOTE: Mount this assembly on either the Low Torque Arm (Item 3) or the High Torque Arm (Item 4) (See Figure 3).

2. Install the Cap Screws (Item 33) and the Lock Washers (Item 34) (See Figure 3).
3. Tighten the Cap Screws (Item 33) to 57-74 Nm [42-55 ft-lb] torque.

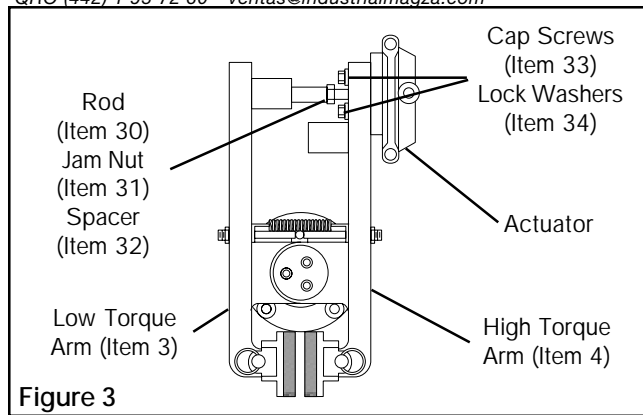

Figure 3

FRAME

1. Locate the SPC Brake in the desired position in relation to the disc. The brake shoes need to be mounted with approximately [1/16 inches] 1.6 mm space between the outside edge of the shoe and the disc O.D.

NOTE: If the SPC Brake is air engaged, apply air to the brake to lock it into position in relation to the disc. If the SPC Brake is spring engaged, release the brake by applying 5.2-6.9 bar [75-100 psi] air pressure. Locate the brake shoes onto the disc and release the air pressure to lock the brake in place.

2. Align the frame on the customer supplied support so the brake arms are parallel with the brake disc and the brake shoes are positioned at least 1.6 mm [1/16 inches] in from the disc edge.

NOTE: The support must be capable of sustaining loads produced during braking.

If shims are used under the Frame (Item 1) mounting pads, care must be taken to prevent warping of the Frame when tightening the Cap Screws (Item 17).

3. Release the SPC Brake from the disc.
4. Tighten the Cap Screws (Item 17) and the Lock Washers (Item 20) to 67.8 Nm [50 ft-lb] torque (See Figure 4).

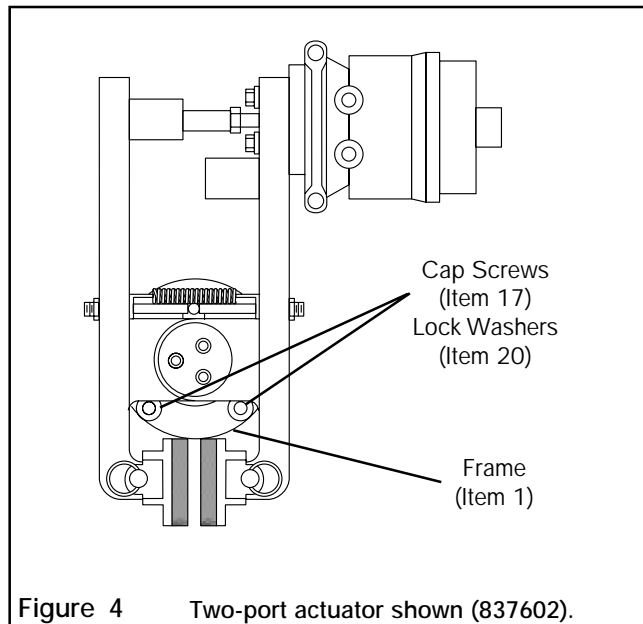

Figure 4 Two-port actuator shown (837602).

CAUTION

The Cap Screws (Item 17) must sustain the loads produced by the mounting torque. The torque rating specified above allows a significant load safety factor. **DO NOT OVER TORQUE THE CAP SCREWS.**

FRICITION FACING ADJUSTMENT

AIR ACTUATED

1. Loosen the Jam Nut (Item 19) (See Figure 5).
2. Turn the Adjustment Screw (Item 18) counterclockwise until a 0.79 mm [1/32 inch] customer supplied spacer can be inserted between each Friction Facing (Item 6) and the disc. Each side may be adjusted individually (See Figure 5).
3. With customer supplied spacers inserted, turn each Adjustment Screw (Item 18) clockwise until a resistance is felt (See Figure 5).

NOTE: There should be a gap of 0.79 mm [1/32 inch] between each Friction Facing and the disc.

4. Remove the customer supplied spacers and tighten the Jam Nut (Item 19) to 20.3-27 Nm [15-20 ft-lb] torque (See Figure 5).
5. Loosen the Jam Nut (Item 31) (See Figure 5).
6. Adjust the Spacer (Item 32) until its spherical end touches the Block (Item 21) (See Figure 5).
7. Tighten the Jam Nut (Item 31) to 20.3-27 Nm [15-20 ft-lb] torque (See Figure 5).

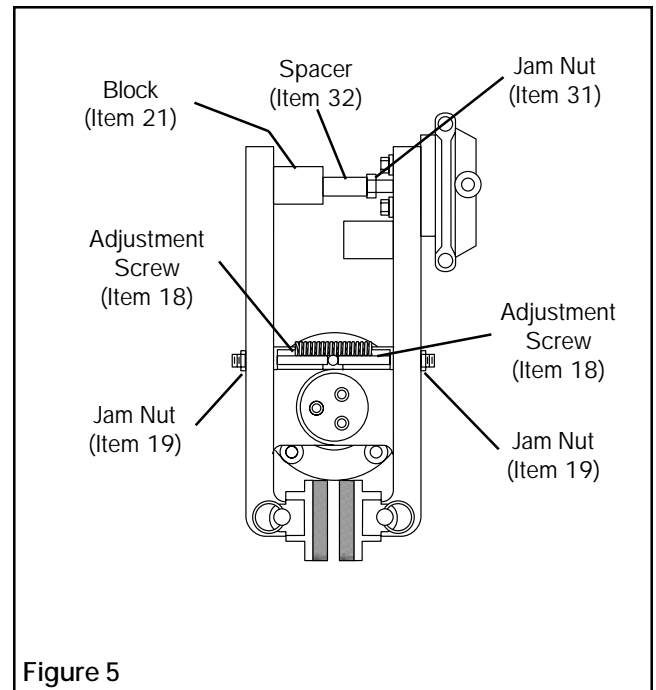

Figure 5

SPRING ACTUATED

NOTE: Friction facing adjustment on spring actuated unit is accomplished by applying hold-off pressure of 5.2-6.9 bar [75-100 psi] to release the spring actuator.

1. Manually release spring actuators (See Figure 6).
2. Apply hold-off air pressure. This will remove any tension on the Tap Bolt for easier release.

NOTE: Before performing step three, determine the actuator type and select either step 3a or 3b. Step four returns to general instructions used for both models.

OBSOLETE THREE-PORT ACTUATOR ONLY

- 3a. Using a 9/16 inch socket wrench, turn the tap bolt counterclockwise until the brake is released (approximately 40 turns). Hold-off air pressure can be removed at this time and service performed. (Refer to Figure 6a)

TWO PORT ACTUATOR ONLY

- 3b. Using a 3/4 inch socket, turn the tap bolt counterclockwise to fully cage (compress) the spring. The spring is fully compressed when the bolt is backed out of the unit 21 mm [0.83 inches]. (Refer to Figure 6b).

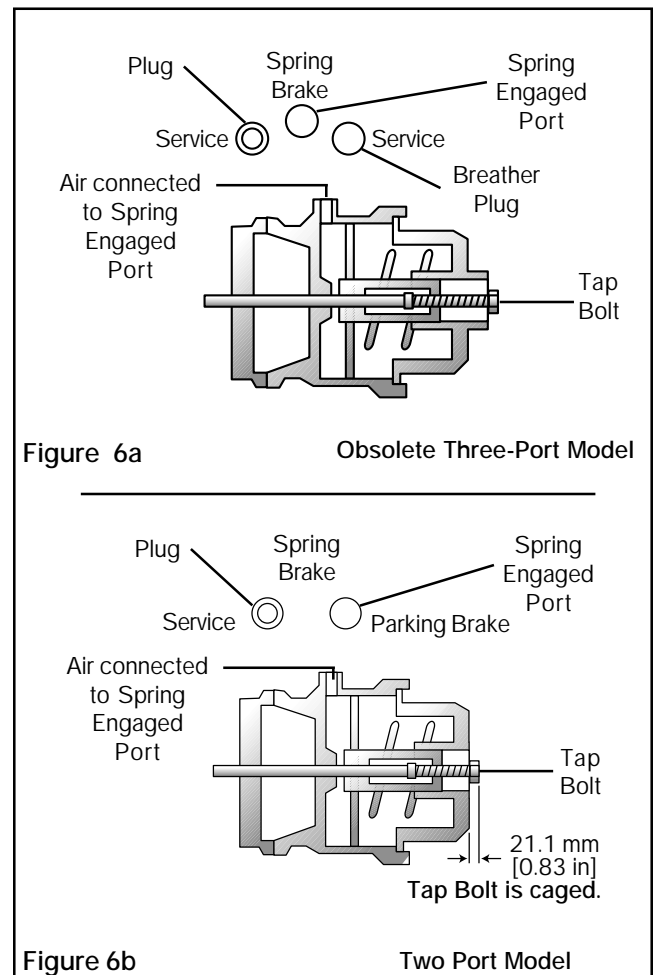

Figure 6a

Obsolete Three-Port Model

Figure 6b

Two Port Model

4. Loosen the Jam Nut (Item 19) (See Figure 7).
5. Turn each Adjustment Screw (Item 18) counterclockwise until a 0.79 mm [1/32 inch] customer supplied spacer can be inserted between each Friction Facing and the disc. Each side may be adjusted individually (See Figure 7).
6. With customer supplied spacers inserted, turn the Adjustment Screw (Item 18) clockwise until a resistance is felt (See Figure 7).

NOTE: There should be a gap of 0.79 mm [1/32 inch] between each Friction Facing and the disc.

7. Remove the customer supplied spacers and tighten the Jam Nut (Item 19) to 20.3-27 Nm [15-20 ft-lb].
8. Loosen the Jam Nut (Item 31) (See Figure 7).
9. Adjust the Spacer (Item 32) until its spherical end touches the Block (Item 21) (See Figure 7).
10. Tighten the Jam Nut (Item 31) to 20.2-40.5 Nm [15-30 ft-lb] torque (See Figure 7).
11. Engage the power spring.

NOTE: Ensure proper hold-off pressure has been maintained. (This will remove any tension on the tap bolt for easier release.)

NOTE: Before performing step thirteen, determine the actuator type and select either step 13a or 13b. Step fourteen returns to general instructions used for both models.

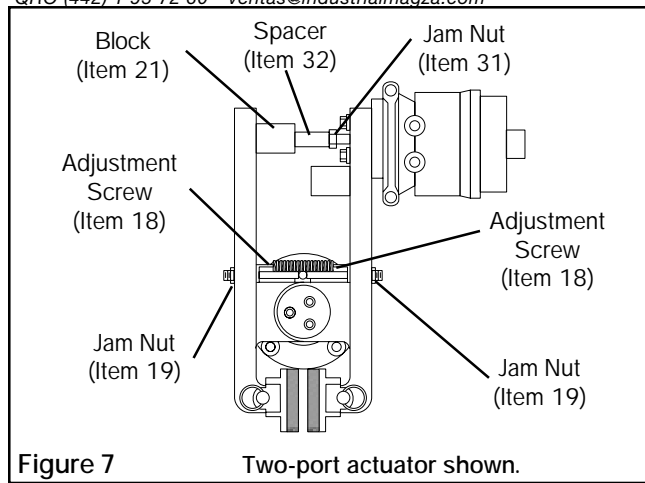

Figure 7 Two-port actuator shown.

OBSELETE THREE-PORT ACTUATOR ONLY

- 13a. Using a 9/16 inch socket, turn the top bolt clockwise until it bottoms out (approximately 40 turns), then torque the Tap Bolt to 13.5-20.2 Nm [10-15 ft-lb].

TWO-PORT ACTUATOR ONLY

- 13b. Using a 3/4 inch socket, turn the tap bolt clockwise to fully uncase (decompress the spring. The spring is fully decompressed when the hex bolt head is flush against the actuator.
14. Remove hold-off pressure.

AIR CONNECTIONS

Pneumatically actuated devices require clean, pressure regulated, and lubricated air for maximum performance and long life. Your Nexen Distributor carries filters, regulators, and lubricators specifically designed to operate with Nexen clutches, brakes, and valves.

Piping diagrams are included in this manual for a variety of braking functions. Refer to OPERATIONAL MODES.

The Actuator air connections may be rotated 360° by loosening the Ring Clamp and rotating the Actuator Head.

NOTE: Tighten the Ring Clamp Bolts to 33.7-47.3 Nm [25-35 ft-lb] torque.

A Hose Assembly (Item 35) is supplied and must be connected to the brake with sufficient slack to allow the arms full freedom of movement without putting undue stress on the hose or hose connections.

DANGER

Actuator (spring engaged units only) is spring loaded under extreme pressure. Do not disassemble Actuator. If Actuator malfunctions, replace the Actuator or contact Nexen. The tap bolt beneath the actuator breather cap can be used to physically release the spring.

CAUTION

Do not use rigid pipe or tubing when connecting directly to the Brake. Care must also be taken to prevent an unshielded air hose from rubbing on metal surfaces or edges, as this will cause rapid deterioration of the hose.

LUBRICATION

All pivot points on the Single Post Caliper Brake use self-lubricated high PV bearings.

For tension control applications where the disc is held at elevated temperatures for extended periods, use a light machine oil on Bearings (Items 10, 11, and 12) (See Figure 8).

The sliding spherical contact between the Block (Item 21) and Spacer (Item 32) should be lubricated with a molybdenum disulfide-based grease (See Figure 8).

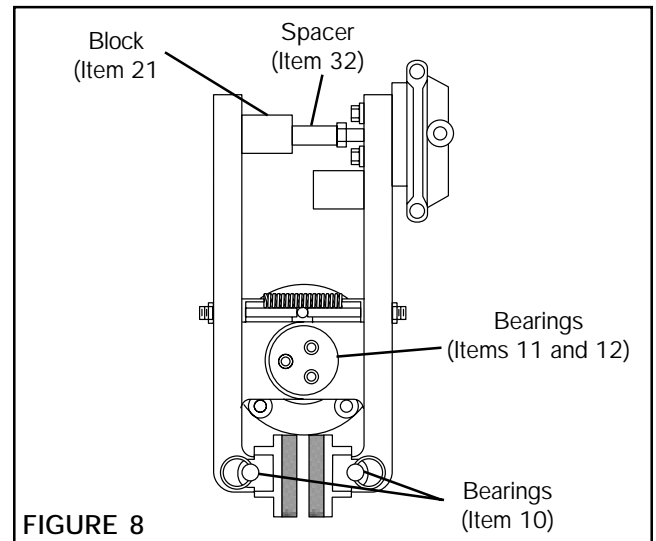

OPERATIONAL MODES

NORMAL SERVICE MODE

Below is a standard air brake control circuit. On-off air control is achieved by the 3-Way Valve. Torque is accomplished by the regulation of air pressure.

NOTE: Maximum operating pressure is 6.9 bar [100 psi] (See Figure 9).

NORMAL SPRING ENGAGED MODE

This mode is for occasional duty, non-cyclic applications only. A hold-off pressure of 5.2-6.9 bar [75-100 psi] is used to compress the spring inside the Actuator canister. A control signal is used to release the hold-off pressure, thus applying full spring engaged torque to the brake (See Figure 9).

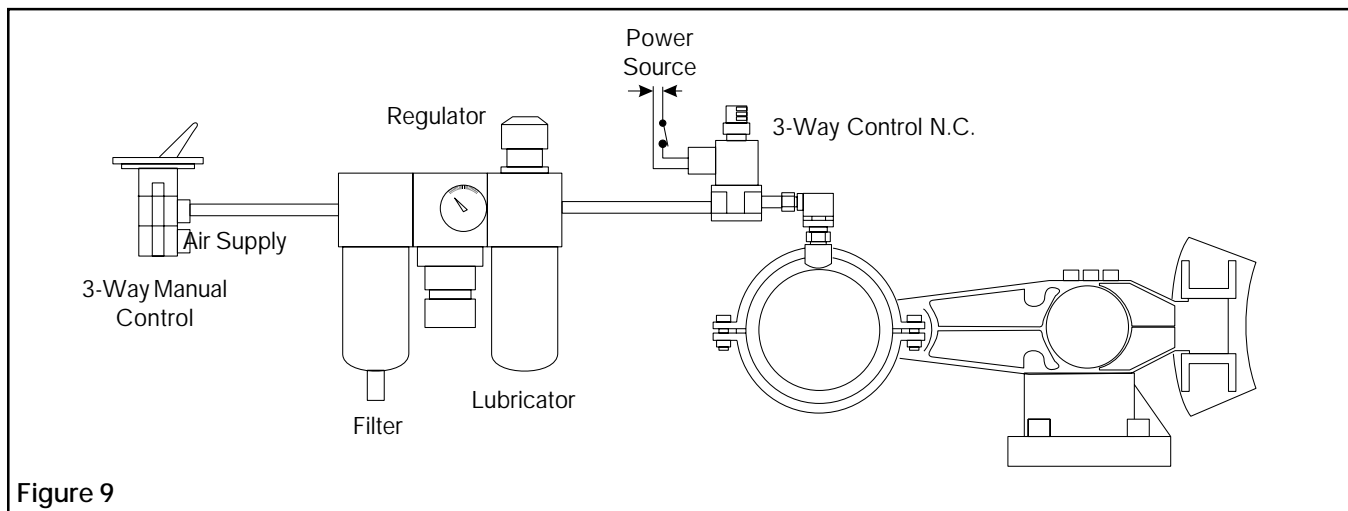

Figure 9

SPRING ENGAGED-DUAL AIR MODE

This mode allows the selection of any value of spring engaged torque (from zero to full scale) available with a particular disc size by relieving a percentage of the minimum Hold-Off pressure 5.2 bar [75 psi]. The remaining pressure, balanced against the spring force, reduces the output of the Actuator (See Figure 11).

EXAMPLE: A standard spring set brake with a 24 inch disc has a full rated spring engaged torque of 3,360 Nm [30,000 in-lb] when using the minimum hold-off pressure of 75 psi [5.2 bar]. If it is desired to have 60% of this torque or 2,016 Nm [18,000 in-lb], relieve the hold-off pressure 60 percent or 3.1 bar [45 psi], leaving 2.1 bar [30 psi] hold-off pressure.

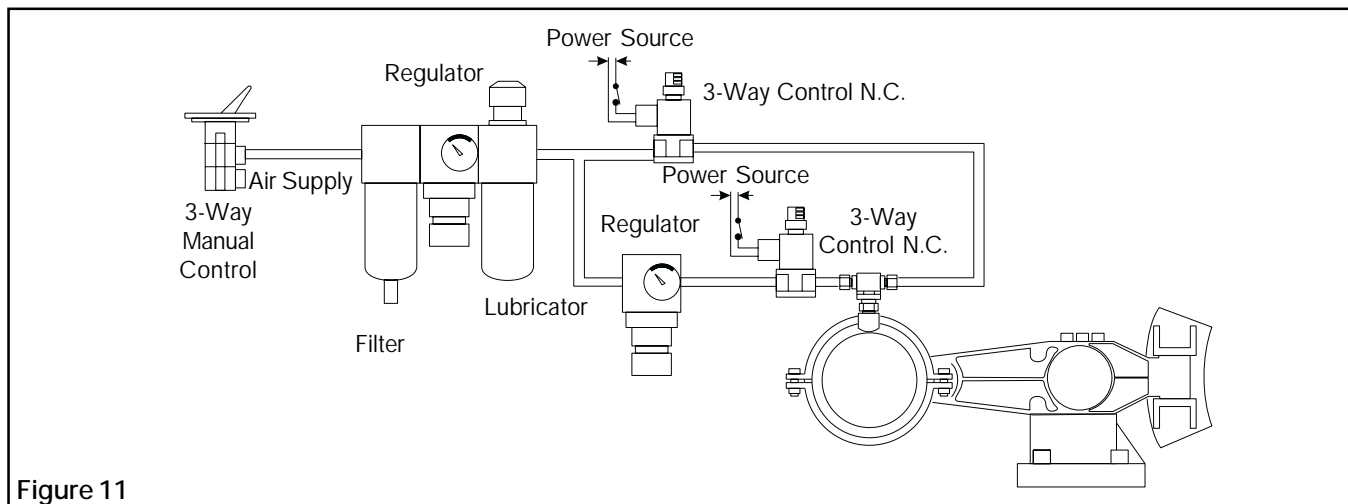

Figure 11

MAINTENANCE

MANUAL RELEASE

OBSOLETE THREE-PORT ACTUATOR ONLY

NOTE: The tap bolt beneath the actuator breather cap can be used to physically release the spring in the event of actuator failure or machine service without hold off air available. **DO NOT USE THE TAP BOLT TO ADJUST THE friction facing GAP.** If the actuator (spring engaged units only) is damaged and air pressure will not release the brake, use a 9/16 inch socket wrench to turn the tap bolt counterclockwise until the brake is released (approximately 40 turns).

DISENGAGEMENT

1. If a manual release for safety reasons is needed, first apply hold off air pressure to remove any tension on the Tap bolt for easier release.
2. Using a 9/16 inch socket wrench, turn the tap bolt counterclockwise until the brake is released (approximately 40 turns).
3. Hold off air pressure can be removed at this time and service performed.

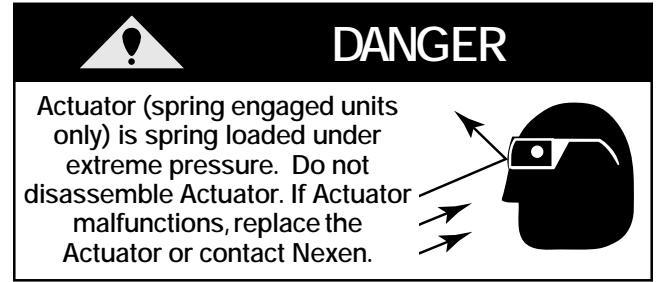

RE-ENGAGEMENT

1. To reengage the actuator, apply hold off air pressure.
2. Turn the tap bolt clockwise until seated (approximately 40 turns).
3. Torque the tap bolt to 13.6-20.34 Nm [10-15 ft-lb].
4. Remove hold off air pressure.

TWO-PORT ACTUATOR ONLY

NOTE: The Hex bolt on the top of the actuator canister can be used to physically release the spring in the event of actuator failure or machine service without hold off air available. **DO NOT USE THE HEX BOLT TO ADJUST FRICTION FACING GAP.** This will lower torque capabilities. If the actuator (spring-engaged units only) is damaged and air pressure will not release the brake, use a 3/4 inch socket wrench to turn the tap bolt counterclockwise until the brake is released. The spring is fully compressed when the bolt is backed out approximately 21.1 mm [0.83 inches].

DISENGAGEMENT

1. If a manual release for safety reasons is needed, first apply hold off air pressure to remove any tension on the Tap bolt for easier release.
2. Using a 3/4 inch socket, turn the tap bolt counterclockwise to fully cage (compress) the spring. The spring is fully compressed when the bolt is backed out of the unit 21 mm [0.83 inches]. (Refer to Figure 6b).
3. Hold off air pressure can be removed at this time and service performed.

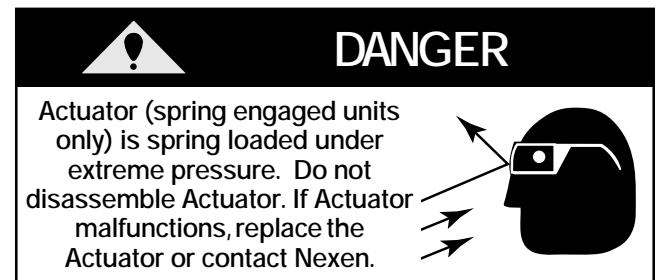

RE-ENGAGEMENT

1. To reengage the actuator, apply hold off air pressure.
2. Using a 3/4 inch socket, turn the tap bolt clockwise to fully uncage (decompress the spring). The spring is fully decompressed when the hex bolt head is flush against the actuator.
3. Remove hold off air pressure.

GENERAL

1. Adhere to the following bolt tightening torques (See Table 3).
2. Inspect Actuator exterior. Replace the Actuator if it is damaged.
3. Check tightness of all air line connections, and condition of all air lines. Replace worn or damaged air lines.
4. Inspect Friction Facings for wear. Replace if it is worn to approximately 7.93 mm [5/16 inch] thick.
5. Lubricate items requiring lubrication (See LUBRICATION).

TABLE 3

ITEM No.	DESCRIPTION	TORQUE Nm [ft-lb]
15	Machine Screw (Friction Facing)	12-16 [8-11]
17	Cap Screw (Frame Mounting)	67.5 [50]
19	Jam Nut (Adjustment Screw)	20.3-27 [15-20]
24	Cap Screw (Retaining Plate)	34-44 [25-33]
31	Jam Nut (Spacer)	20.3-27 [15-20]
33	Cap Screws (Actuator)	57.2-74.8 [42-55]
-	Actuator Clamp Ring, Bolt & Nut	33.7-47.3 [25-35]
-	Tap Bolt (Spring-Engaged Unit)	13.5-20.2 [10-15]

PARTS REPLACEMENT

FRICION FACINGS

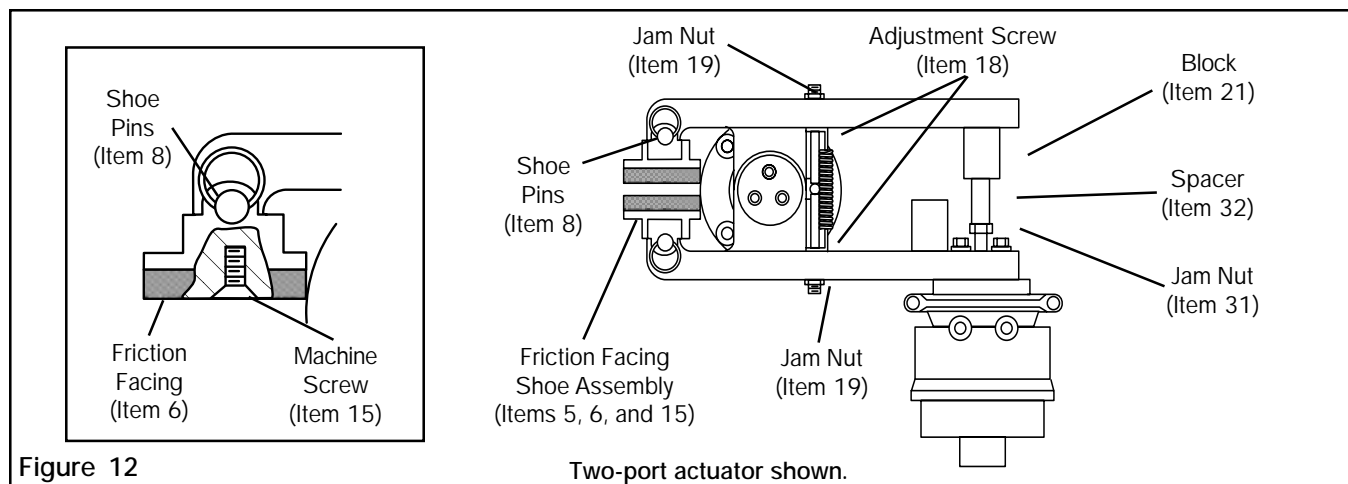

Figure 12

Two-port actuator shown.

NOTE: When replacing Friction Facings, inspect the Friction Disc for scoring or grooves. If necessary, the Rotor may be turned. A maximum of 0.76 mm [0.030 inches] may be removed from each side of the Friction Disc before it is necessary to replace the Friction Disc.

1. Manually release the spring actuators (See Figure 12).
2. Apply hold-off air pressure. This will remove any tension on the Tap Bolt for easier release.

NOTE: Before performing step three, determine the actuator type and select either step 3a or 3b. Step four returns to general instructions used for both models.

OBSOLETE THREE-PORT ACTUATOR ONLY

- 3a. Using a 9/16 inch socket wrench, turn the tap bolt counterclockwise until the brake is released (approximately 40 turns). Hold-off air pressure can be removed at this time and service performed.

TWO PORT ACTUATOR ONLY

- 3b. Using a 3/4 inch socket, turn the tap bolt counterclockwise to fully cage (compress) the spring. The spring is fully compressed when the bolt is backed out of the unit 21mm [0.83 inches].
4. Remove the Shoe Pins (Item 8) (See Figure 12).
5. Remove the Friction Facing Shoe Assembly (Items 5, 6, and 15) (See Figure 12).

NOTE: The Machine Screws are assembled with an anaerobic locking compound. Inserting a properly fitting screwdriver into the head of the Machine Screw and striking the screwdriver with a hammer will break the crystalline structure of this locking compound and allow removal of the Machine Screws. Never use an impact wrench to remove the Machine Screws.

6. Remove the old Machine Screws (Item 15) and old Friction Facings (Item 6).
7. Using new Machine Screws (Item 15), install new Friction Facings (Item 6) (See Figure 12).
8. Tighten the new Machine Screws (Item 15) to 12-16 Nm [8-11 ft-lb] torque.
9. Reinstall the Friction Facing Shoe Assembly (Items 5, 6, and 15) and Shoe Pins (Item 8).
10. Perform Friction Facing clearance adjustment (See FRICTION FACING ADJUSTMENT).

BEARINGS

1. Manually release the spring actuators (See Figure 13).
2. Apply hold-off air pressure. This will remove any tension on the Tap Bolt for easier release.

NOTE: Before performing step three, determine the actuator type and select either step 3a or 3b. Step four returns to general instructions used for both models.

OBSELETE THREE-PORT ACTUATOR ONLY

- 3a. Using a 9/16 inch socket wrench, turn the tap bolt counterclockwise until the brake is released (approximately 40 turns). Hold-off air pressure can be removed at this time and service performed.

TWO-PORT ACTUATOR ONLY

- 3b. Using a 3/4 inch socket, turn the tap bolt counterclockwise to fully cage (compress) the spring. the spring is fully compressed when the bolt is backed out of the unit 21mm [0.83 inches].
4. Remove the Spring (Item 14) (See Figure 13).
5. Remove the Shoe Pins (Item 8), and Friction Facing Shoe Assembly (Items 5, 6, and 15) (See Figure 13).
6. Remove the three Cap Screws (Item 24) (See Figure 13).
7. Remove the top Retaining Plate (Item 13) (See Figure 13).
8. Remove the Low Torque Arm (Item 3) containing one old Thrust Bearing (Item 12) and the High Torque Arm (Item 4) containing the second old Thrust Bearing (Item 12) out of the Pivot Pin (Item 2) (See Figure 13).
9. Remove the two old Thrust Bearings (Item 12) from the Torque Arms (Items 3 and 4) (See Figure 13)
10. Press the old Bearings (Items 10 and 11) out of the Arms (Items 3 and 4).
11. Press new Bearings (Item 10 and 11) into the Arms (Items 3 and 4) (See Figure 13).
12. Install the new Thrust Bearings (Item 12) (See Figure 13).
13. Reinstall the Low Torque Arm (Item 3) containing one new Thrust Bearing (Item 12) and the High Torque Arm (Item 4) containing the second new Thrust Bearing (Item 12) onto the Pivot Pin (Item 2) (See Figure 13).

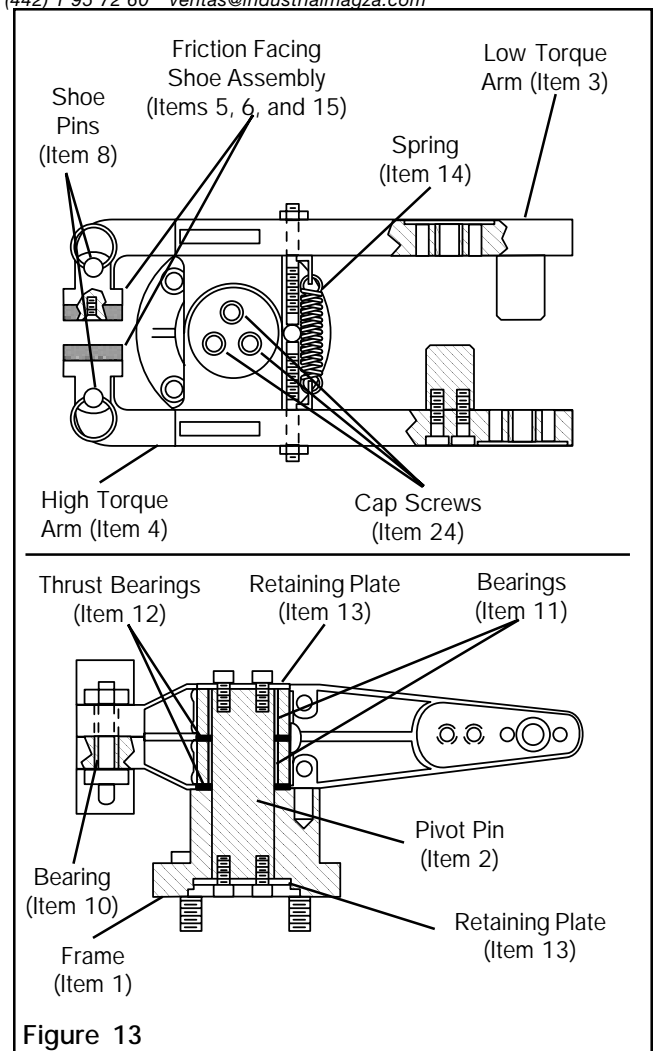

Figure 13

14. Reinstall the top Retaining Plate (Item 13) (See Figure 13).
15. Reinstall the three Cap Screws (Item 24) (See Figure 13).
16. Tighten the Cap Screws (Item 24) to 34-44 Nm [25-33 ft-lb] torque.
17. Reinstall Friction Facing Shoe Assembly (Items 5, 6, and 15) and Shoe Pins (Item 8) (See Figure 13).
18. Reinstall the Spring (Item 14) (See Figure 13).

NOTE: The Frame (Item 1) and Pivot Pin (Item 2) must be flush on the bottom before installing the Retaining Plates (Item 13) and the Cap Screws (Item 24).

REPLACEMENT PARTS

The Item or balloon number for all Nexen products is used for part identification on all product parts lists, product price lists, unit assembly drawings, bills of materials, and instruction manuals.

When ordering replacement parts, specify model designation, item number, part description, and quantity. Purchase replacement parts through your local Nexen Distributor.

PARTS LIST

BRAKE

ITEM	DESCRIPTION	QTY
1	Frame	1
3	Arm (Low Torque)	1
4	Arm (High Torque)	1
5	Shoe	2
6 ^{1,2}	Friction Facing	2
7	Spring Holder	2
8	Shoe Pin	2
9	Dowel Pin	1
10 ¹	Bearing	4
11 ¹	Bearing	2
12 ¹	Thrust Bearing	2
13	Retaining Ring	1
14 ¹	Spring	1
15 ^{1,2}	Machine Screw	8
16	Cap Screw	2
17	Cap Screw	4
18	Adjustment Screw	2
19	Jam Nut	2
20	Lock Washer	4
21	Block	2
22	Cap Screw	4
24	Cap Screw	3
46	Bushing	2

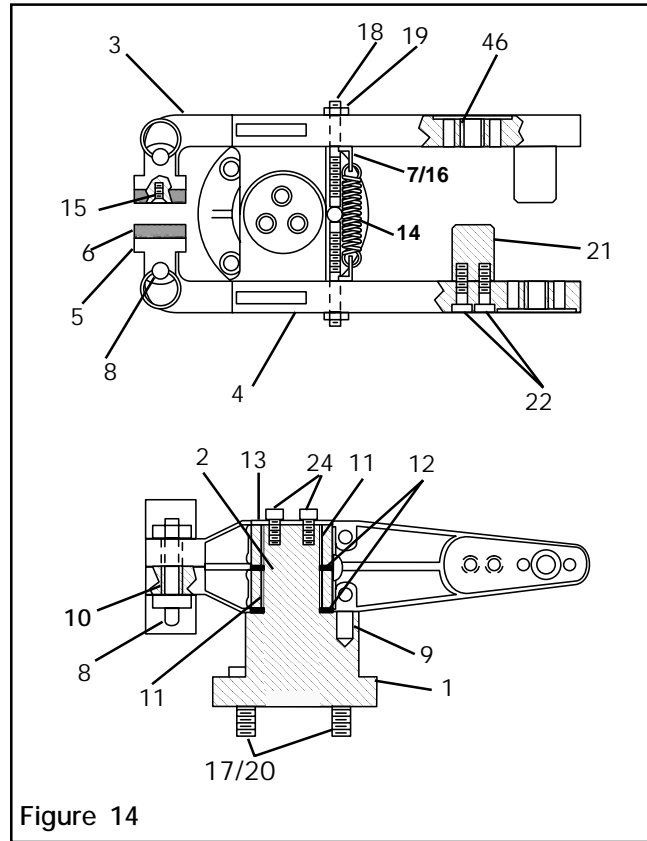

Figure 14

AIR ACTUATOR

ITEM	DESCRIPTION	QTY
25	Cap	1
26	Clamp	1
27	Bottom	1
28	Diaphragm	1
29	Piston Assembly	1
30	Rod	1
31	Jam Nut	1
32	Spacer	1
33	Cap Screw	2
34	Lock Washer	2
35	Hose Assembly (Not Shown)	1
36	Fitting Connector (Not Shown)	1
37	Fitting Bushing (Not Shown)	1

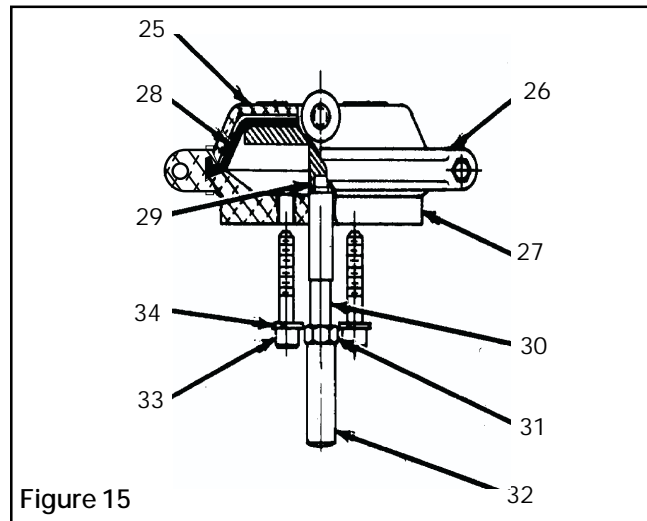

Figure 15

OBSOLETE THREE-PORT ACTUATOR

ITEM	DESCRIPTION	QTY
31	Jam Nut	1
32	Spacer	1
33	Cap Screw	2
34	Lock Washer	2
35	Hose Assembly (Not Shown)	1
36	Fitting Connector (Not Shown)	1
37	Fitting Bushing (Not Shown)	1
40	Spring Actuator	1
41	Clamp	1
42	Bottom	1
43	Rod	1
44	Bearing	1
45	Fitting Plug	2

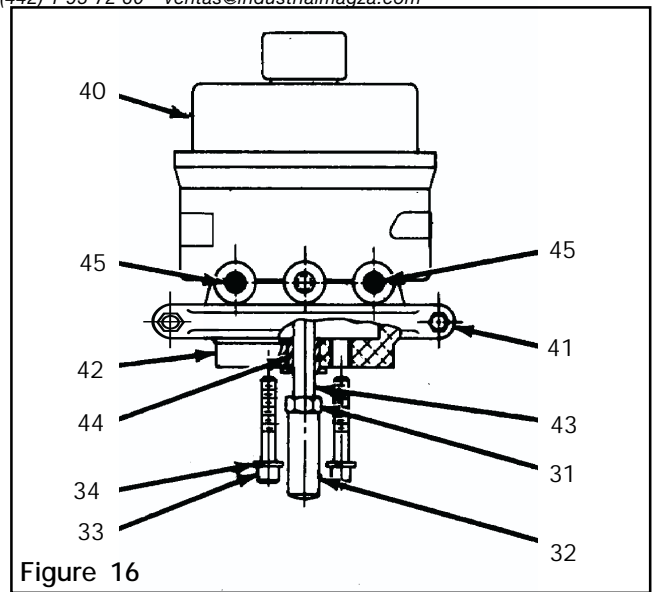

Figure 16

DANGER

Actuator (spring engaged units only) is spring loaded under extreme pressure. Do not disassemble Actuator. If Actuator malfunctions, replace the Actuator or contact Nexen.

TWO-PORT SPRING ACTUATOR

ITEM	DESCRIPTION	QTY
31	Jam Nut	1
32	Spacer	1
33	Cap Screw	2
34	Lock Washer	2
35	Hose Assembly (Not Shown)	1
36	Fitting Connector (Not Shown)	1
37	Fitting Bushing (Not Shown)	1
40	Spring Actuator	1
41	Clamp	1
42	Bottom	1
43	Rod	1
44	Bearing	1
45	Fitting Plug	2

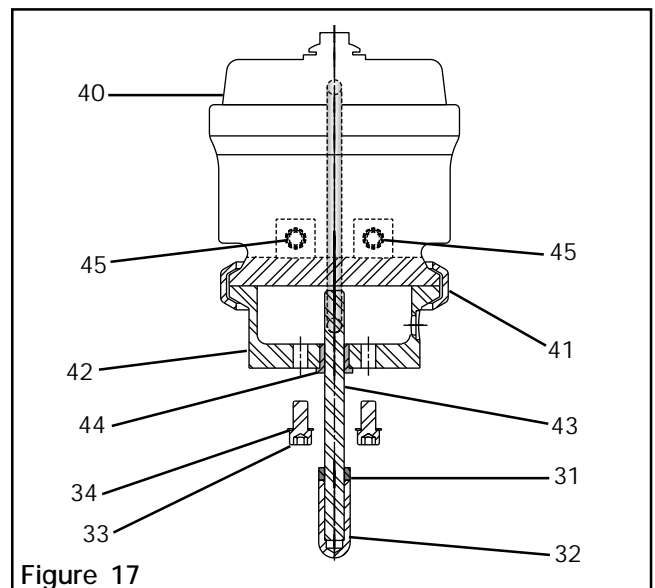

Figure 17

WARRANTY

Warranties

Nexen warrants that the Products will be free from any defects in material or workmanship for a period of 12 months from the date of shipment. NEXEN MAKES NO OTHER WARRANTY, EXPRESS OR IMPLIED, AND ALL IMPLIED WARRANTIES, INCLUDING WITHOUT LIMITATION, IMPLIED WARRANTIES OF MERCHANTABILITY AND FITNESS FOR A PARTICULAR PURPOSE ARE HEREBY DISCLAIMED. This warranty applies only if (a) the Product has been installed, used and maintained in accordance with any applicable Nexen installation or maintenance manual for the Product; (b) the alleged defect is not attributable to normal wear and tear; (c) the Product has not been altered, misused or used for purposes other than those for which it was intended; and (d) Buyer has given written notice of the alleged defect to Nexen, and delivered the allegedly defective Product to Nexen, within one year of the date of shipment.

Exclusive Remedy

The exclusive remedy of the Buyer for any breach of the warranties set out above will be, at the sole discretion of Nexen, a repair or replacement with new, serviceably used or reconditioned Product, or issuance of credit in the amount of the purchase price paid to Nexen by the Buyer for the Products.

Limitation of Nexen's Liability

TO THE EXTENT PERMITTED BY LAW NEXEN SHALL HAVE NO LIABILITY TO BUYER OR ANY OTHER PERSON FOR INCIDENTAL DAMAGES, SPECIAL DAMAGES, CONSEQUENTIAL DAMAGES OR OTHER DAMAGES OF ANY KIND OR NATURE WHATSOEVER, WHETHER ARISING OUT OF BREACH OF WARRANTY OR OTHER BREACH OF CONTRACT, NEGLIGENCE OR OTHER TORT, OR OTHERWISE, EVEN IF NEXEN SHALL HAVE BEEN ADVISED OF THE POSSIBILITY OR LIKELIHOOD OF SUCH POTENTIAL LOSS OR DAMAGE. For all of the purposes hereof, the term "consequential damages" shall include lost profits, penalties, delay images, liquidated damages or other damages and liabilities which Buyer shall be obligated to pay or which Buyer may incur based upon, related to or arising out of its contracts with its customers or other third parties. In no event shall Nexen be liable for any amount of damages in excess of amounts paid by Buyer for Products or services as to which a breach of contract has been determined to exist. The parties expressly agree that the price for the Products and the services was determined in consideration of the limitation on damages set forth herein and such limitation has been specifically bargained for and constitutes an agreed allocation of risk which shall survive the determination of any court of competent jurisdiction that any remedy herein fails of its essential purpose.

Limitation of Damages

In no event shall Nexen be liable for any consequential, indirect, incidental, or special damages of any nature whatsoever, including without limitation, lost profits arising from the sale or use of the Products.

Warranty Claim Procedures

To make a claim under this warranty, the claimant must give written notice of the alleged defect to whom the Product was purchased from and deliver the Product to same within one year of the date on which the alleged defect first became apparent.

nexen®

Nexen Group, Inc.
560 Oak Grove Parkway
Vadnais Heights, MN 55127

800.843.7445
Fax: 651.286.1099
www.nexengroup.com

ISO 9001 Certified