

Examination of resolution and travel speed

RESOLUTION

$$R = \frac{L}{P \times e}$$

L : Ballscrew Lead (mm)
 P : Number of division per revolution of motor (pulse/r)
 e : Gear reducer ratio
 R : Resolution (least input increment)

Example:

Ballscrew lead: 60 mm
 Number of divisions per revolution of motor: 2000 pulse/r
 Gear reducer ratio: 5
 Resolution = $\frac{60}{2000 \times 5} = 0.006 \text{ mm}$

TRAVEL SPEED

$$V = L \times \frac{N}{e}$$

L : Ballscrew Lead (mm)
 N : Allowable maximum motor speed (r/min)
 e : Gear reducer ratio
 V : Travel speed

Example:

Ballscrew lead: 60 mm
 Allowable motor speed: 3,000 r/min
 Gear reducer ratio: 5
 Travel speed = $60 \times \frac{3000}{5} = 36,000 \text{ mm/min}$
 = 36 m/min = 600 mm/sec

Service Life

Three main components of the linear stage KS are guideway, ballscrew and bearing. The Calculation formulas of their life are shown as follows:

GUIDEWAY

$$L = \left(\frac{f_t}{f_w} \times \frac{C}{P_n} \right)^3 \times 50 \text{ km}$$

L : Life Rating (km)
 C : Basic Dynamic Load Rating (N),1650N
 P_n : Calculating Loading (N)
 f_t : Temperature Coefficient (ref. Table 1)
 f_w : Loading Coefficient (ref. Table 2)

Table 1

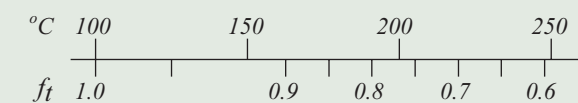

Table 2

Thrust and Vibration	Velocity (V)	f _w
No Thrust	V<15m/min	1 ~ 1.5
Low Vibration	15<V<60m/min	1.5 ~ 2
High Vibration	V<60m/min	2 ~ 3.5

BALLSCREW AND BEARING

$$L = \left(\frac{1}{f_w} \times \frac{C_a}{F_{a,n}} \right)^3 \times 10^6 \text{ rev}$$

L : Life Rating (rev.)
 C_a : Basic Dynamic Load Rating (N),8683N
 F_{a,n} : Axial Loading (N)
 f_w : Loading Coefficient (ref. Table 2)

Example of KS-Type for special applications

EX. 1



EX. 2



EX. 3



EX. 4

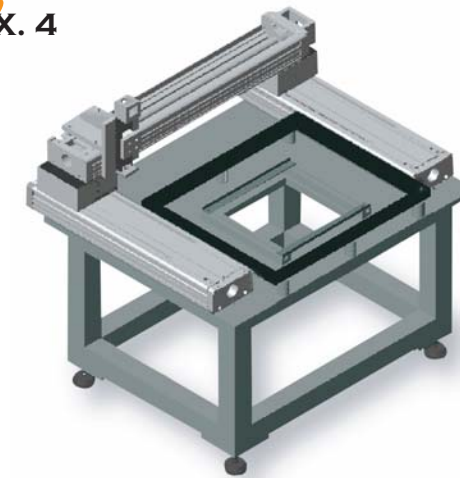

The specifications in this catalog are subject to change without notification.



YOUR 21ST CENTURY PARTNER IN TECHNOLOGY INNOVATION

HIWIN TECHNOLOGIES CORP.
 No. 46, 37th Road
 Taichung Industrial Park
 Taichung 40707, TAIWAN
 Tel : +886-4-23594510
 Fax: +886-4-23594420
 http://www.hiwin.com.tw
 E-mail: business@mail.hiwin.com.tw

HIWIN GmbH
 Brücklesbünd 2, D-77654
 Offenburg, GERMANY
 Tel: +49-781-93278-0
 Fax: +49-781-93278-90
 http://www.hiwin.de
 E-mail: info@hiwin.de

HIWIN JAPAN
 ● **KOBE**
 3F. Sannomiya-Chuo Bldg.
 4-2-20 Goko-Dori, Chuo-Ku
 KOBE 651-0087, JAPAN
 Tel : +81-78-262-5413
 Fax: +81-78-262-5686
 http://www.hiwin.co.jp
 E-mail: info@hiwin.co.jp
 ● **TOKYO**
 Tel: +81-42-358-4501
 Fax: +81-42-358-4519
 ● **CHUBU-EIGYOSHO**
 Tel : +81-587-65-7010
 Fax: +81-587-65-3130
 ● **KUMAMOTO**
 Tel : +81-96-340-2282
 Fax: +81-96-340-2286

HIWIN USA
 ● **CHICAGO**
 520 Business Center Drive
 Mount Prospect, IL 60056, U.S.A.
 Tel : +1-847-8272270
 Fax: +1-847-8272291
 http://www.hiwin.com
 E-mail: info@hiwin.com
 ● **SILICON VALLEY**
 Tel : +1-510-4380871
 Fax: +1-510-4380873



HIWIN SCHWEIZ
 Einsiedlerstrasse 535, 8810 Horgen
 SWITZERLAND
 Tel: +41-43-3550330
 Fax: +41-43-3550331
 http://www.hiwin.ch
 E-mail: info@hiwin.ch

HIWIN CZECH
 Lozibky 15
 61400 Brno,
 CZECH REPUBLIC
 Tel/Fax: +420-5-485-28238
 http://www.hiwin.cz
 E-mail: hiwin@sky.cz



Linear Stage

The **HIWIN** Linear Motion Stage KS is the newest motor-driven ballscrew module equipped with a dust-proof strip to prevent from wear particles from flying out.

NEW Patent Pending
KS TYPE

Based on the dust-proof design, this linear stage is the most suitable product applications in semi-conductor manufacturing, LED testing, or medical equipment.



Features

- Low cost and compact
- Dust-proof designed
- Precision and high speed
- Easy installation
- Design Optimization:
The structure is designed to be extra rigid and extremely lightweight. The FEM Analysis is shown in Figure 1.

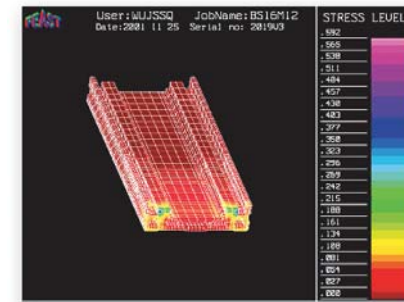
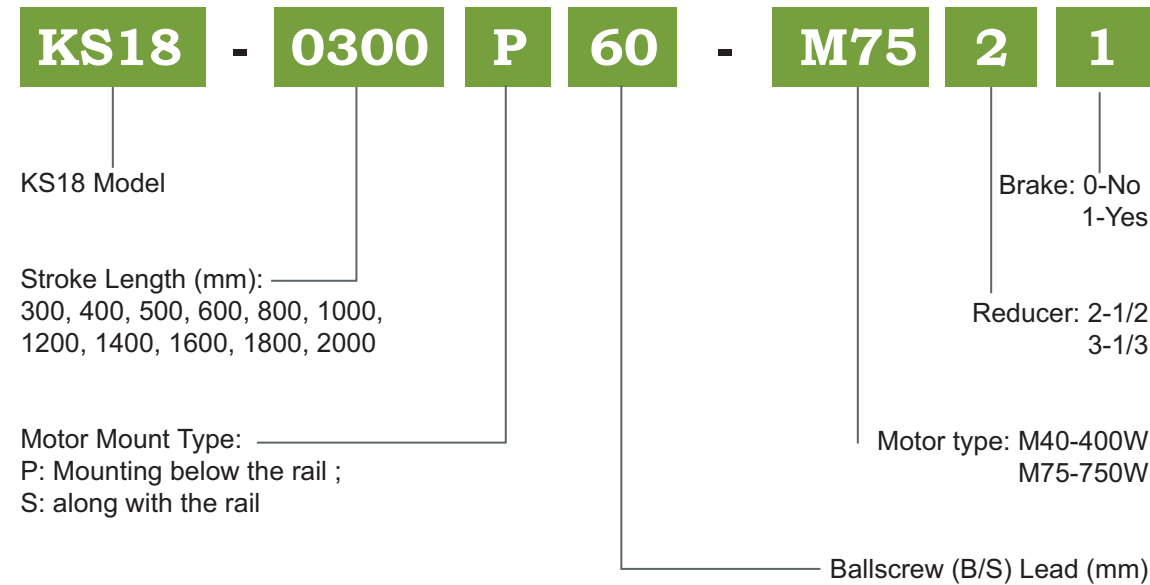

Figure 1.

Applications

- Semi-conductor manufacturing
- LED examination
- Medical equipment
- Wafer movement

Description of Part Number



Note:
For the Motor type and the following Roman numerals, it shows no symbol if the motor will not be needed. Ex: KS18-0300P60

Specification

KS-P type

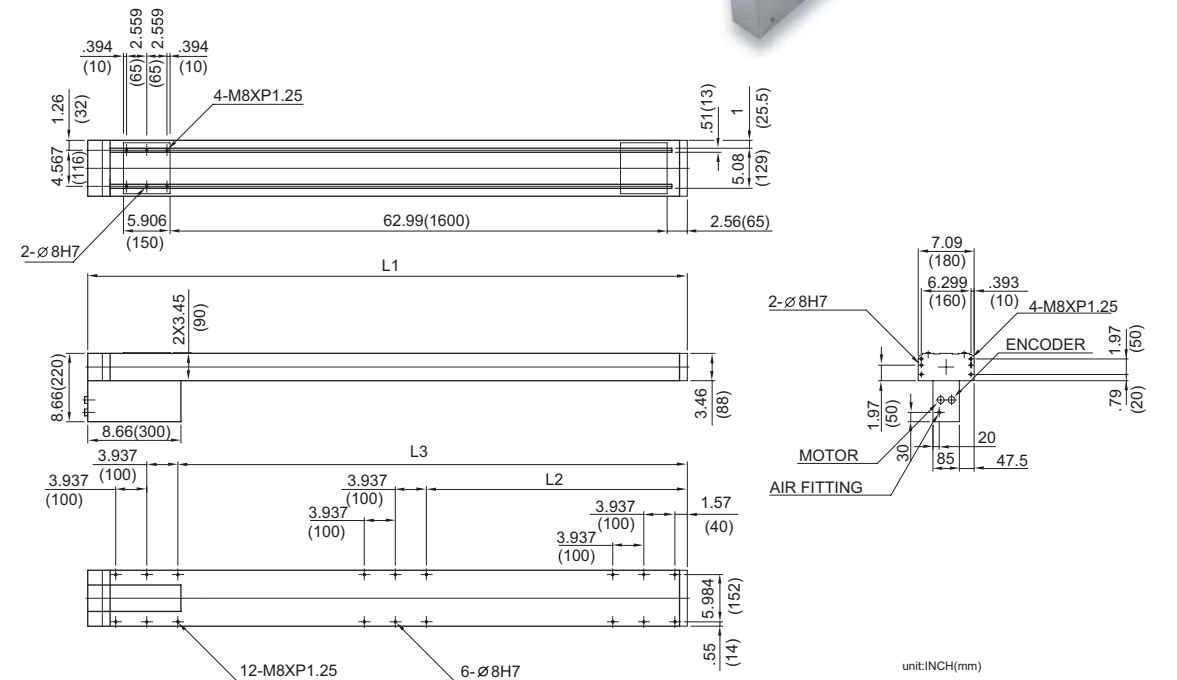

Table1.

Model	Dimensions (mm)			Stroke Length (mm)	Repeatability (mm)	Operation Tem. (°C)	Weight (kg)
	L1	L2	L3				
KS18-030P	630	190	340	300	±0.01	0~40	34
KS18-040P	730	240	440	400	±0.01	0~40	36
KS18-050P	830	290	540	500	±0.01	0~40	38
KS18-060P	930	340	640	600	±0.01	0~40	44
KS18-080P	1130	440	840	800	±0.01	0~40	44
KS18-100P	1330	540	1040	1000	±0.01	0~40	48
KS18-120P	1530	640	1240	1200	±0.01	0~40	52
KS18-140P	1730	740	1440	1400	±0.01	0~40	56
KS18-160P	1930	840	1640	1600	±0.01	0~40	60
KS18-180P	2130	940	1840	1800	±0.01	0~40	64
KS18-200P	2330	1040	2040	2000	±0.01	0~40	68

KS-S type

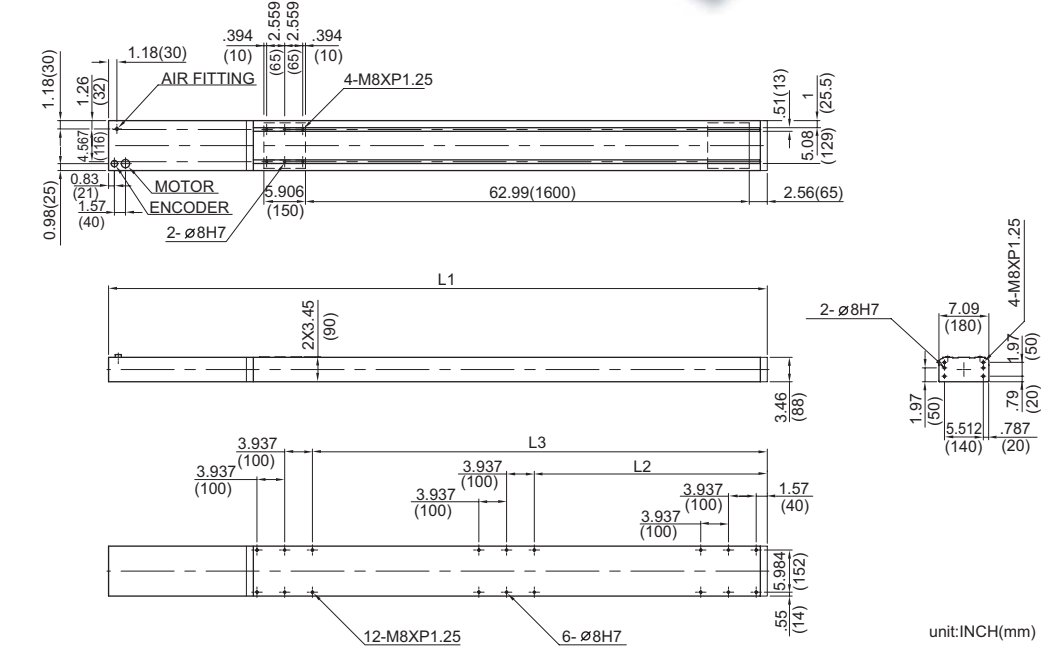

Table2.

Model	Dimensions (mm)			Stroke Length (mm)	Repeatability (mm)	Operation Tem. (°C)	Weight (kg)
	L1	L2	L3				
KS18-030S	1075	190	340	300	±0.01	0~40	34
KS18-040S	1175	240	440	400	±0.01	0~40	36
KS18-050S	1275	290	540	500	±0.01	0~40	38
KS18-060S	1375	340	640	600	±0.01	0~40	40
KS18-080S	1575	440	840	800	±0.01	0~40	44
KS18-100S	1775	540	1040	1000	±0.01	0~40	48
KS18-120S	1975	640	1240	1200	±0.01	0~40	52
KS18-140S	2175	740	1440	1400	±0.01	0~40	56
KS18-160S	2375	840	1640	1600	±0.01	0~40	60
KS18-180S	2575	940	1840	1800	±0.01	0~40	64
KS18-200S	2775	1040	2040	2000	±0.01	0~40	68