

PE CLUTCH ZERO SLIP HIGH TORQUE TOOTH CLUTCH

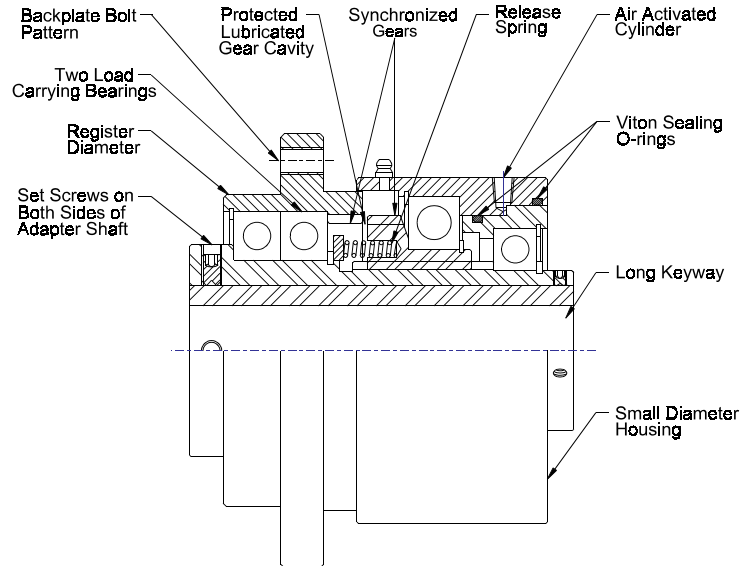

- Air Applied / Spring Release
- High Torque / Compact Design
- Positive Engagement
- Exact Positioning

PE ENGAGEMENT AND DISENGAGEMENT

Air enters the air inlet and is trapped between the two viton O-Rings. This forces the cylinder, thrust bearing, and driving gear plate to move axially and engage the driven gears of the backplate. Both the driving and the driven gears are synchronized, allowing complete and positive engagement under static conditions. Engagement can only occur at 0 RPM.

When air is released from the air chamber, and the clutch is at 0 RPM, the release springs force the cylinder, thrust bearing, and driving gear plate back to its original, disengaged position.

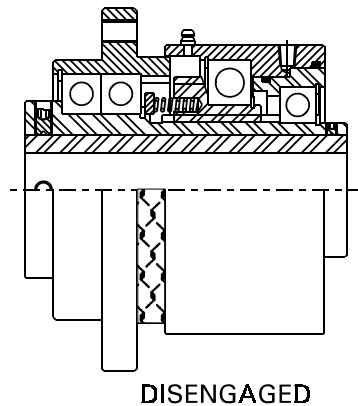
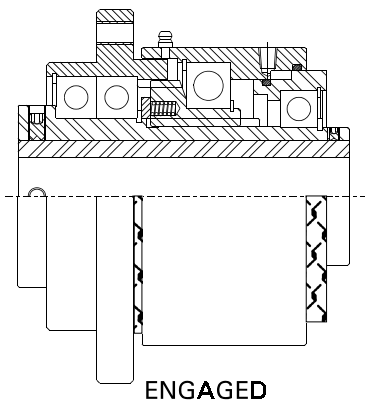

PE AIR APPLIED-SPRING RELEASE CLUTCH

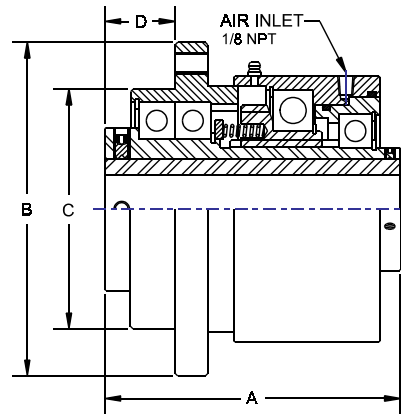
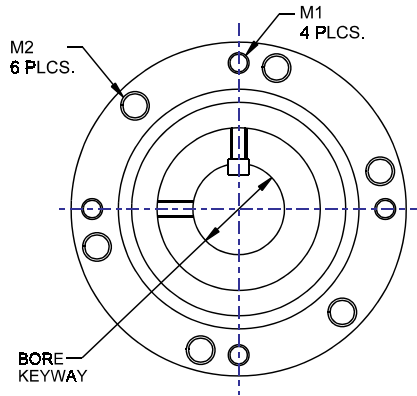

PE

MODEL	BORE +.002 -.001	KEYWAY	A	B	C +.000 -.001	D	M ₁		M ₂		TORQUE IN/LB (Nm)	MAX. RPM	NO. OF TEETH
							TAP	BCD	TAP	BCD			
PE2AS	-1 .750 (19.050)	3/16X1/16 (4.75X1.59)	4.56 (115.82)	4.13 (104.90)	2.875 (73.025)	.938 (23.83)	.25-20	3.437 (87.300)	.313-18	3.562 (90.475)	2,000 (226)	3,600	46
	-2 .875 (22.225)												
PE4AS	-1 1.188 (30.175)	1/4X3/32 (6.35X2.38)	5.19 (131.83)	4.88 (123.95)	3.500 (88.900)	.969 (24.61)	.25-20	4.250 (107.950)	.313-18	4.250 (107.950)	4,000 (452)	3,000	60
	-2 1.250 (31.750)												
PE10AS	-1 1.688 (42.875)	3/8X3/32 (9.53X2.38)	6.06 (153.92)	6.13 (155.70)	4.500 (114.300)	1.16 (29.46)	.313-18	5.250 (133.350)	.50-13	5.375 (136.525)	10,000 (1130)	2,000	48
	-2 1.750 (44.450)												
PE25AS	2.188 (55.575)	1/2X1/8 (12.70X3.18)	7.06 (179.32)	8.00 (203.20)	5.750 (146.050)	1.69 (42.93)	.50-13	7.000 (177.800)	-	-	25,000 (2825)	1,800	58
PE50AS	2.938 (74.625)	3/4X3/16 (19.05X4.75)	8.18 (207.77)	9.50 (241.30)	7.370 (187.198)	2.63 (66.80)	-	-	.50-13	8.500 (215.900)	50,000 (5650)	1,800	78

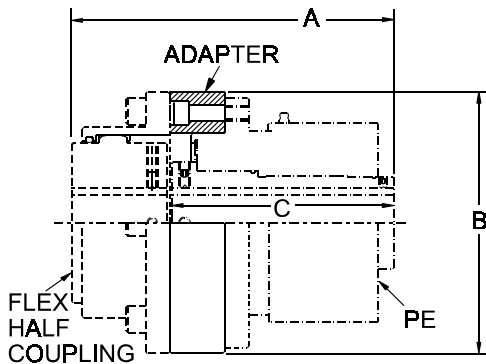

PE WITH COUPLING ADAPTER

MODEL	ADAPTER PART NO.	A	B	C	TORQUE IN/LB (Nm)	MAX. RPM	NO. OF TEETH	FLEX-HALF COUPLING REQUIRED*
PE10 AS/SA	4635A	8.125 (206.375)	6.250 (158.750)	6.063 (154.000)	10,000 (1,130)	2,000	48	1015G
PE25 AS	4636A	10.250 (260.350)	8.375 (212.725)	7.063 (179.400)	25,000 (2,825)	1,800	58	1025G
PE50 AS	4637A	12.563 (319.100)	9.438 (239.725)	8.812 (223.825)	50,000 (15,600)	1,800	78	1030G

* Flex-Half Coupling supplied by customer (Falk or Equivalent)

NOTE: UNIT WILL NOT DISENGAGE UNDER LOAD

PE Clutches use O-rings as dynamic seals, therefore adequate lubrication must be provided in the actuating air circuit to ensure these O-rings do not run dry.